



# Outdoor Knight Boiler Installation & Operation Manual

Models: 151 - 286



IMG00363



**⚠ WARNING**

This manual must only be used by a qualified heating installer / service technician. Read all instructions, including this manual and the Outdoor Knight Boiler Service Manual, before installing. Perform steps in the order given. Failure to comply could result in severe personal injury, death, or substantial property damage.

Save this manual for future reference.



# Contents

<b>HAZARD DEFINITIONS</b> .....	2	<b>5. FIELD WIRING</b>	
<b>PLEASE READ BEFORE PROCEEDING</b> .....	3	Line Voltage Connections .....	28
<b>THE OUTDOOR KNIGHT BOILER -- HOW IT WORKS</b>	4-6	Low Voltage Connections .....	28
<b>RATINGS</b> .....	7	Wiring of the Cascade.....	30
<b>1. DETERMINE BOILER LOCATION</b>		<b>6. CONDENSATE DISPOSAL</b>	
Provide Clearances.....	9	Condensate Drain .....	32
Corrosive Contaminants and Sources .....	9	<b>7. STARTUP</b> .....	33-38
<b>2. PREPARE BOILER</b>		<b>8. OPERATING INFORMATION</b>	
Remove Boiler from Wood Pallet.....	10	General.....	39
Gas Conversions.....	10-11	Cascade .....	42
Leveling the Boiler .....	11	Sequence of Operation .....	43-44
<b>3. HYDRONIC PIPING</b>		Outdoor Knight Boiler Control Module .....	45
System Water Piping Methods.....	12	Status Display Screens.....	46-48
Low Water Cutoff Device .....	12	<b>9. MAINTENANCE</b>	
Chilled Water System.....	12	Maintenance and Annual Startup.....	49-53
Freeze Protection .....	12	<b>10. DIAGRAMS</b>	
General Piping Information .....	12	Ladder Diagram .....	54
Relief Valve / T & P Installation .....	13	Wiring Diagram.....	55
Near Boiler Piping Components.....	13-14	Revision Notes .....	Back Cover
Near Boiler Piping Connections .....	14		
Circulator Sizing.....	14		
Variable Speed Pump Option .....	16		
<b>4. GAS CONNECTIONS</b>			
Connecting Gas Supply Piping .....	24-25		
Natural Gas .....	25		
Pipe Sizing for Natural Gas .....	25		
Natural Gas Supply Pressure Requirements .....	25		
Propane Gas .....	25		
Pipe Sizing for Propane Gas.....	25		
Propane Supply Pressure Requirements .....	25		
Check Inlet Gas Supply .....	26		
Gas Pressure .....	27		
Gas Valve Replacement .....	27		

## Hazard definitions

The following defined terms are used throughout this manual to bring attention to the presence of hazards of various risk levels or to important information concerning the life of the product.

**⚠ DANGER** DANGER indicates an imminently hazardous situation which, if not avoided, will result in death or serious injury.

**⚠ WARNING** WARNING indicates a potentially hazardous situation which, if not avoided, could result in death or serious injury.

**⚠ CAUTION** CAUTION indicates a potentially hazardous situation which, if not avoided, may result in minor or moderate injury.

**CAUTION** CAUTION used without the safety alert symbol indicates a potentially hazardous situation which, if not avoided, may result in property damage.

**NOTICE** NOTICE indicates special instructions on installation, operation, or maintenance that are important but not related to personal injury or property damage.

## Please read before proceeding

### ⚠ WARNING

**Installer** – Read all instructions, including this manual and the Outdoor Knight Boiler Service Manual, before installing. Perform steps in the order given.

**User** – This manual is for use only by a qualified heating installer/service technician. Refer to the User's Information Manual for your reference.

Have this boiler serviced/inspected by a qualified service technician, at least annually.

Failure to comply with the above could result in severe personal injury, death or substantial property damage.

### NOTICE

When calling or writing about the boiler – Please have the boiler model and serial number from the boiler rating plate.

Consider piping and installation when determining boiler location.

Any claims for damage or shortage in shipment must be filed immediately against the transportation company by the consignee.

Factory warranty (shipped with unit) does not apply to units improperly installed or improperly operated.

### ⚠ WARNING

Failure to adhere to the guidelines on this page can result in severe personal injury, death, or substantial property damage.

### ⚠ WARNING

If the information in this manual is not followed exactly, a fire or explosion may result causing property damage, personal injury or loss of life.

This appliance **MUST NOT** be installed in any location where gasoline or flammable vapors are likely to be present.

#### WHAT TO DO IF YOU SMELL GAS

- Do not try to light any appliance.
- Do not touch any electric switch; do not use any phone in your building.
- Immediately call your gas supplier from a near by phone. Follow the gas supplier's instructions.
- If you cannot reach your gas supplier, call the fire department.
- Installation and service must be performed by a qualified installer, service agency, or the gas supplier.

### When servicing boiler –

- To avoid electric shock, disconnect electrical supply before performing maintenance.
- To avoid severe burns, allow boiler to cool before performing maintenance.

### Boiler operation –

- Do not block flow of combustion or ventilation air to the boiler.
- Should overheating occur or gas supply fail to shut off, do not turn off or disconnect electrical supply to circulator. Instead, shut off the gas supply at a location external to the appliance.
- Do not use this boiler if any part has been under water. The possible damage to a flooded appliance can be extensive and present numerous safety hazards. Any appliance that has been under water must be replaced.

### Boiler water –

- Thoroughly flush the system (without boiler connected) to remove sediment. The high-efficiency heat exchanger can be damaged by build-up or corrosion due to sediment.
- Continual fresh make-up water will reduce boiler life. Mineral buildup in the heat exchanger reduces heat transfer, overheats the stainless steel heat exchanger, and causes failure. Addition of oxygen carried in by makeup water can cause internal corrosion in system components. Leaks in boiler or piping must be repaired at once to prevent makeup water.

### ⚠ CAUTION

Do not use petroleum-based cleaning or sealing compounds in the boiler system. Gaskets and seals in the system may be damaged. This can result in substantial property damage.

### ⚠ CAUTION

Do not use “homemade cures” or “boiler patent medicines”. Serious damage to the boiler, personnel, and/or property may result.

### Freeze protection fluids –

- NEVER use automotive antifreeze. Use only inhibited propylene glycol solutions, which are specifically formulated for hydronic systems. Ethylene glycol is toxic and can attack gaskets and seals used in hydronic systems.

# The Outdoor Knight Boiler - How it works...

- 1. Stainless steel heat exchanger**  
 Allows system water to flow through specially designed coils for maximum heat transfer, while providing protection against flue gas corrosion. The coils are encased in a jacket that contains the combustion process.
- 2. Combustion chamber access cover**  
 Allows access to the combustion side of the heat exchanger coils.
- 3. Blower**  
 The blower pulls in air and gas through the venturi (item 5). Air and gas mix inside the blower and are pushed into the burner, where they burn inside the combustion chamber.
- 4. Gas valve**  
 The gas valve senses the negative pressure created by the blower, allowing gas to flow only if the gas valve is powered and combustion air is flowing.
- 5. Venturi**  
 The venturi controls air and gas flow into the burner.
- 6. Flue gas sensor (limit rated)**  
 This sensor monitors the flue gas exit temperature. The control module will modulate and shut down the boiler if flue gas temperature gets too hot. This protects the flue pipe from overheating.
- 7. Boiler outlet temperature sensor (housed with the high limit sensor)**  
 This sensor monitors boiler outlet water temperature (system supply). If selected as the controlling sensor, the control module adjusts boiler firing rate so the outlet temperature is correct.
- 8. Boiler inlet temperature sensor**  
 This sensor monitors return water temperature (system return). If selected as the controlling sensor, the control module adjusts the boiler firing rate so the inlet temperature is correct.
- 9. Temperature and pressure gauge (field installed, not shown)**  
 Monitors the outlet temperature of the boiler as well as the system water pressure.
- 10. Electronic LCD display**  
 The electronic display consists of 4 buttons, a navigation dial and a multiple line liquid crystal display.
- 11. Flue pipe adapter**  
 Allows for the connection of the vent system to the boiler.
- 12. Burner (not shown)**  
 Made with metal fiber and stainless steel construction, the burner uses pre-mixed air and gas and provides a wide range of firing rates.
- 13. Water outlet (system supply)**  
 NPT water connection that supplies hot water to the system, either 1" or 1-1/4", depending on the model.
- 14. Water inlet (system return)**  
 NPT water connection that returns water from the system to the heat exchanger, either 1" or 1-1/4", depending on the model.
- 15. Gas connection pipe**  
 Threaded pipe connection, either 1/2" or 3/4", depending on the model. This pipe should be connected to the incoming gas supply for the purpose of delivering gas to the boiler.
- 16. SMART SYSTEM Control Module**  
 The SMART SYSTEM Control responds to internal and external signals and controls the blower, gas valve, and pumps to meet the heating demand.
- 17. Manual air vent**  
 Designed to remove trapped air from the heat exchanger coils.
- 18. High voltage junction box**  
 The junction box contains the connection points for the line voltage power and all pumps.
- 19. Boiler drain port**  
 Location from which the heat exchanger can be drained.
- 20. Low voltage connection board**  
 The connection board is used to connect external low voltage devices.
- 21. Low voltage wiring connections**  
 Conduit connection points for the low voltage connection board.
- 22. Condensate drain connection**  
 Connects the condensate drain line to a 1/2" PVC union.
- 23. Access cover - top front**  
 Provides protection of the control panel / display from outside elements.
- 24. Access cover - bottom front**  
 Provides access to the burner.
- 25. Ignition electrode**  
 Provides direct spark for igniting the burner.
- 26. Flame inspection window**  
 The quartz glass window provides a view of the burner surface and flame.
- 27. Relief valve**  
 Protects the heat exchanger from an over pressure condition. The relief valve provided with the unit is set at 30 psi.
- 28. Flame sensor**  
 Used by the control module to detect the presence of burner flame.
- 29. Line voltage wiring connections**  
 Conduit connection points for the high voltage junction box.
- 30. Top access cover**  
 Provides access to the internal components.
- 31. Power switch**  
 Turns 120 VAC ON/OFF to the boiler.
- 32. Leveling legs**  
 Used to allow the heat exchanger to be leveled. This is needed for the proper draining of the condensate from the combustion chamber.
- 33. Air pressure switch**  
 The air pressure switch detects blocked inlet conditions.
- 34. Transformer**  
 The transformer provides 24V power to the integrated control.
- 35. High limit sensor (housed with the outlet temperature sensor)**  
 Device that monitors the outlet water temperature. If the temperature exceeds its setting, the integrated control will break the control circuit, shutting the boiler down.
- 36. Gas shutoff switch**  
 An electrical switch designed to cut power to the gas valve to prevent releasing any gas.
- 37. Over-temp switch (Model 286 Only) (located underneath access cover)**  
 An electrical switch designed to shut down boiler operation in the event the outer back of the heat exchanger, directly above the flue connection exceeds 604°F (318°C). This is a one time switch and could warrant a heat exchanger replacement. Check the integrity of the rear refractory at the back of the upper coil if the switch opens.
- 38. Air cover**  
 Covers the over-temp switch and the flue collar with flue sensor.
- 39. Flue pipe assembly**  
 Factory supplied components for a complete venting system.

# The Outdoor Knight Boiler - How it works... *(continued)*

Models 151 - 211

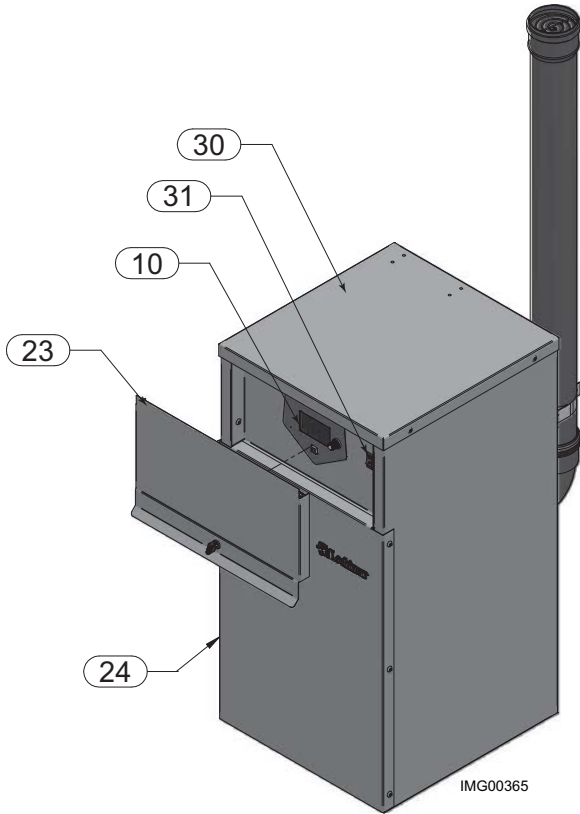

Front View - Models 151 - 211

IMG00365

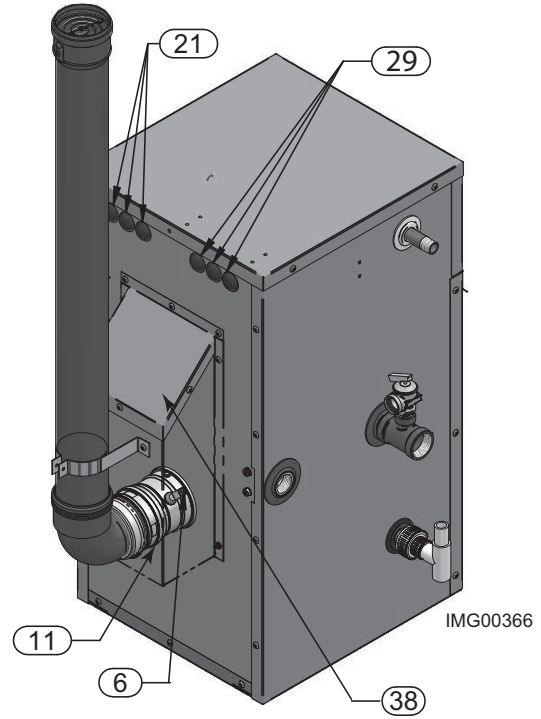

Rear View - Models 151 - 211

IMG00366

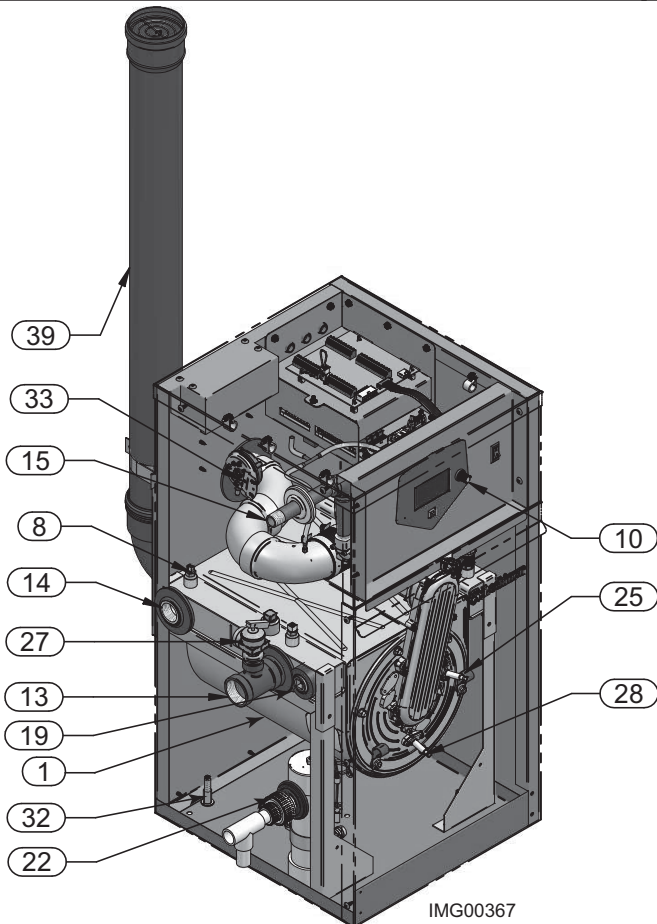

Left Side (inside unit) - Models 151 - 211

IMG00367

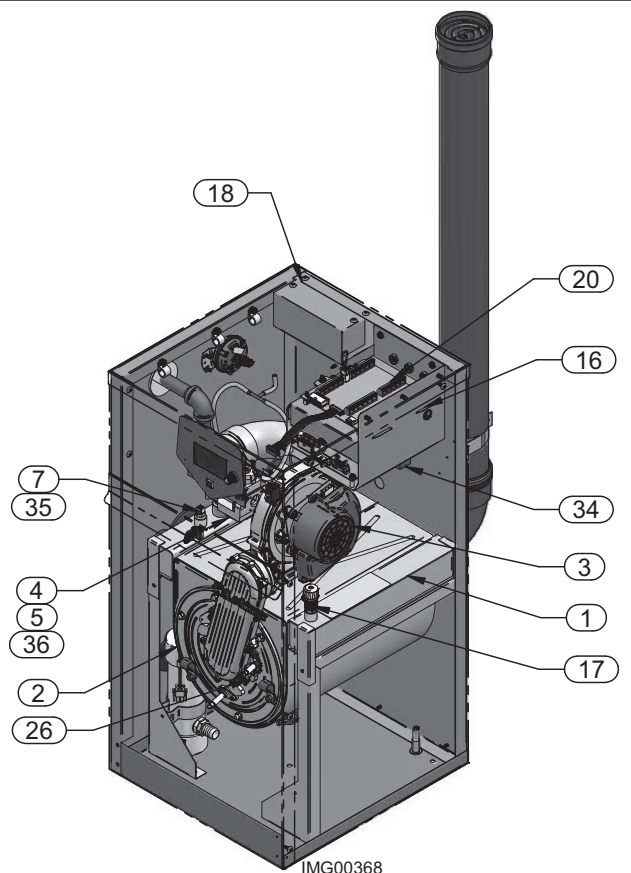

Right Side (inside unit) - Models 151 - 211

IMG00368

# The Outdoor Knight Boiler - How it works...

## Model 286

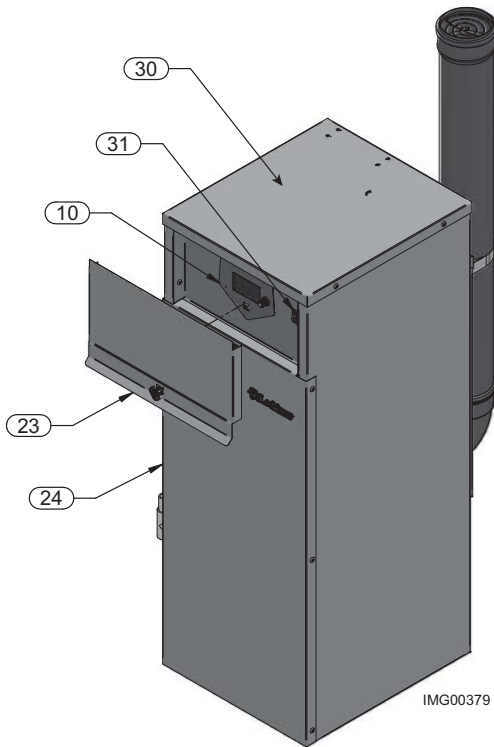

IMG00379

Front View - Model 286

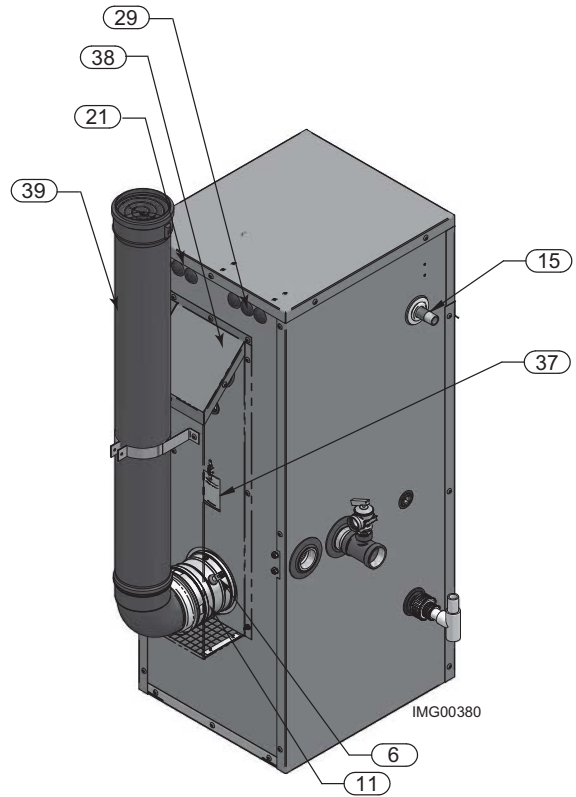

IMG00380

Rear View - Model 286

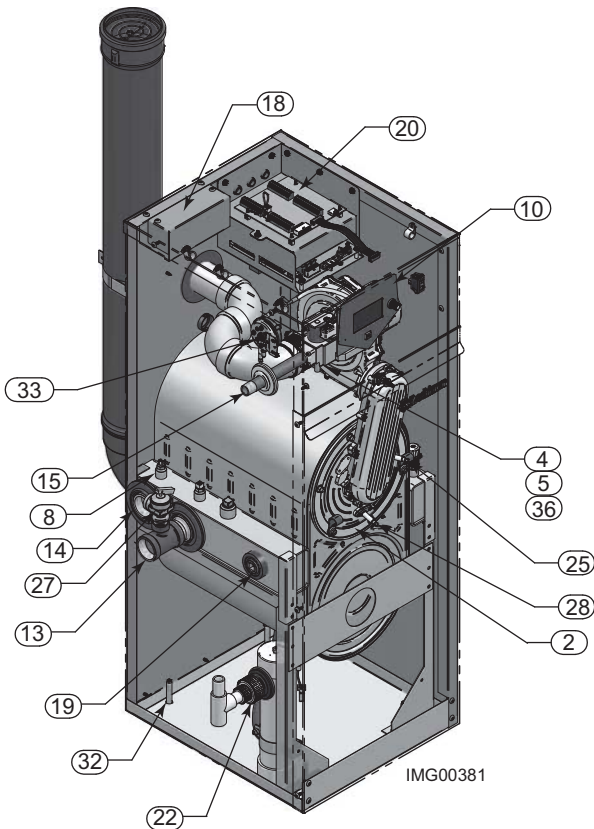

IMG00381

Left Side (inside unit) - Model 286

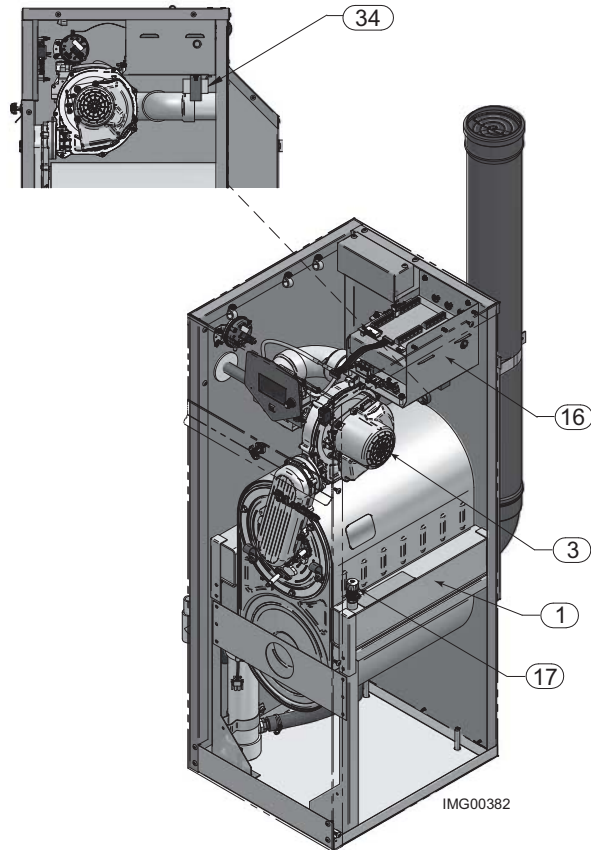

IMG00382

Right Side (inside unit) - Model 286

# Ratings

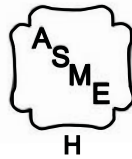

DOE



Outdoor Knight Boiler AHRI Rating						Other Specifications			
Model Number  Note: Change "N" to "L" for L.P. gas models.	Input MBH  (Note 4)		Heating Capacity MBH	Net AHRI Ratings Water, MBH	AFUE %	Boiler Water Content Gallons	Water Connections	Gas Connections	Air Size
	Max	Min	(Note 2,5)	(Note 3,5)	(Note 1, 5)				
OKN151	30	150	141	122	94	1.3	1"	1/2"	3"
OKN211	42	210	197	171	94	1.7	1"	1/2"	3"
OKN286	57	285	266	232	94	2.4	1-1/4"	3/4"	4"

**NOTICE**

Maximum allowed working pressure is located on the rating plate.

**Notes:**

- As an Energy Star Partner, Lochinvar has determined that outdoor boilers meet the Energy Star guidelines for energy efficiency.
- The ratings are based on standard test procedures prescribed by the United States Department of Energy.
- Net AHRI ratings are based on net installed radiation of sufficient quantity for the requirements of the building and nothing need be added for normal piping and pickup. Ratings are based on a piping and pickup allowance of 1.15.
- Standard outdoor boilers are equipped to operate from sea level to 4,500 feet **only** with no adjustments. The boiler will de-rate by 4% for each 1,000 feet above sea level up to 4,500 feet.
- Ratings have been confirmed by the Hydronics Section of AHRI.
- Outdoor boilers temperature controls comply with the requirements of CSD-1 Section CW-400 requirements. The manual reset high limit provided with the outdoor boiler is listed to UL353.

# 1 Determine boiler location

Installation must comply with:

- Local, state, provincial, and national codes, laws, regulations, and ordinances.
- National Fuel Gas Code, ANSI Z223.1 – latest edition.
- Standard for Controls and Safety Devices for Automatically Fired Boilers, ANSI/ASME CSD-1, when required.
- National Electrical Code.

## NOTICE

The Outdoor Knight gas manifold and controls met safe lighting and other performance criteria when the boiler underwent tests specified in ANSI Z21.13 – latest edition.

## WARNING

Outdoor models must be installed outdoors only and must use the outdoor vent kit assembly supplied by the manufacturer. Personal injury or product damage may result if any other cap is used or if an outdoor model is used indoors. All covers, doors and jacket panels must be properly installed to ensure proper operation and prevent a hazardous situation.

## CAUTION

This product contains a condensate management and disposal system that may be subject to freezing if exposed to sustained temperatures below 32°F. Precautions should be taken to protect the condensate trap and drain lines during extended periods of outdoor temperatures below 32°F.

Before locating the boiler, check:

1. Check for nearby connection to:
  - Water piping
  - Gas supply piping
  - Electrical power
2. - Keep venting areas free of obstructions.  
 - Keep area clean and free of combustible and flammable materials.  
 - To avoid a blocked air inlet or blocked flue condition, keep the outdoor air inlet and flue outlet clear of leaves, debris, etc.

## CAUTION

Do not install outdoor models directly on the ground. You must install the outdoor unit on a concrete, brick, block or pressure-treated wood platform.

## CAUTION

Do not locate unit so that high winds can deflect off of adjacent walls, buildings or shrubbery causing recirculation. Recirculation of flue products may cause operational problems, bad combustion or damage to controls. Locate unit at least 3 feet (0.91m) from any wall or vertical surface to prevent wind conditions from affecting performance.

The outdoor unit must not be installed in an area that is enclosed by walls or a fence that will block free wind movement around the unit. Free movement of wind around the outdoor unit is required to carry away the flue products and provide combustion air. The flue outlet/combustion air inlet of an outdoor unit must not be installed closer than 10 feet from an inside corner of an L-shaped structure. Walls or enclosed fencing may cause eddy currents which can recirculate the flue products into the combustion air inlet. Recirculation of flue products may cause operational problems, bad combustion or non-warrantable damage to controls.

## WARNING

- Do not install the outdoor unit under a deck.
- Do not install an outdoor unit in a well, stairwell, alcove, courtyard or other recessed area.
- Do not install outdoor units on stack frames.

Failure to comply with the above could result in severe personal injury, death or substantial property damage.

## CAUTION

- Do not install outdoor units in locations where rain from building runoff drains will spill onto the unit.
- Do not locate the outdoor unit so that water from sprinklers may spray directly onto it. Water may damage controls or other electrical components.

3. Check area around the boiler. Remove any combustible materials, gasoline and other flammable liquids.

## WARNING

Failure to keep the boiler area clear and free of combustible materials, gasoline and other flammable liquids and vapors can result in severe personal injury, death or substantial property damage.

4. If a new boiler will replace an existing boiler, check for and correct system problems, such as:
  - System leaks causing oxygen corrosion or heat exchanger cracks from hard water deposits.
  - Incorrectly-sized expansion tank.
  - Lack of freeze protection in boiler water causing system and boiler to freeze and leak.



# 1 Determine boiler location *(continued)*

Provide clearances:

## Clearances from combustible materials

- Hot water pipes—at least 1/4" (6 mm) from combustible materials.
- Vent pipes—minimum of 14" (356mm) from the rear and 0" on the right side from combustible materials.

## Clearances for service access

- If you do not provide the minimum clearances, it may not be possible to service the boiler without removing it from the space.

## Recommended service clearances:

Front	-	24" (610mm)
Top	-	24" (610mm)
Left side	-	24" (610mm)
Rear	-	24" (610mm)

## Outdoor vent / air intake location

### **⚠ WARNING**

The flue products discharged from the flue outlet on the outdoor vent may be very hot. Avoid touching or other direct contact with the flue gases or the vent termination assembly. These components are hot and direct contact can result in burns.

To prevent recirculation of the flue products into the combustion air inlet, follow all instructions in this section.

Flue gas condensate can condense on exterior walls or on the vent. Some discoloration to exterior building or unit surfaces can be expected. Adjacent brick or masonry surfaces should be protected with a rust resistant sheet metal plate.

Maintain a minimum of 24" (610mm) clearance to the side of the air inlet.

Locate the outdoor vent termination at least 48" (1.22m) below and 48" (1.22m) horizontally from any window, door, walkway or gravity air intake.

Locate outdoor unit at least 10 feet (3.05m) away from any forced air inlet.

Multiple outdoor unit installations require 24" (.61m) clearance between each vent termination.

Clearances around outdoor installations can change with time. Do not allow the growth of trees, shrubs or other plants to obstruct the proper operation of the outdoor vent system.

## Flooring and foundation

### Flooring

The Outdoor Knight is approved for installation on combustible flooring.

### **⚠ WARNING**

Do not install the boiler on carpeting even if foundation is used. Fire can result, causing severe personal injury, death, or substantial property damage.

Under no circumstances is the manufacturer to be held responsible for water damage in connection with this appliance, or any of its components. If flooding is possible, elevate the boiler sufficiently to prevent water from reaching the boiler.

### Prevent combustion air contamination

Do not install unit in locations that can allow contamination of combustion air. Refer to Table 1A for products and areas which may cause contaminated combustion air.

**Table 1A Corrosive Contaminants and Sources**

Products to avoid:
Spray cans containing chloro/fluorocarbons
Permanent wave solutions
Chlorinated waxes/cleaners
Chlorine-based swimming pool chemicals
Calcium chloride used for thawing
Sodium chloride used for water softening
Refrigerant leaks
Paint or varnish removers
Hydrochloric acid/muriatic acid
Cements and glues
Antistatic fabric softeners used in clothes dryers
Chlorine-type bleaches, detergents, and cleaning solvents found in household laundry rooms
Adhesives used to fasten building products and other similar products
Areas likely to have contaminants
Dry cleaning/laundry areas and establishments
Swimming pools
Metal fabrication plants
Beauty shops
Refrigeration repair shops
Photo processing plants
Auto body shops
Plastic manufacturing plants
Furniture refinishing areas and establishments
New building construction
Remodeling areas
Garages with workshops

## 2 Prepare boiler

### Remove boiler from wood pallet

1. After removing the outer shipping carton from the boiler, remove the installation kit.
2. Remove the front access covers to access the lag bolts in front of the unit (FIG. 2-1).
3. To remove the boiler from the pallet (after removing the front access covers):
  - a. Remove the two lag bolts from the wood pallet inside the boiler (FIG. 2-1).
  - b. Detach the boiler from the lag bolts in the rear of the unit, see FIG. 2-1.

#### NOTICE

Do not drop the boiler or bump the jacket on the floor or pallet. Damage to the boiler can result.

**Figure 2-1** Boiler Mounted on Shipping Pallet

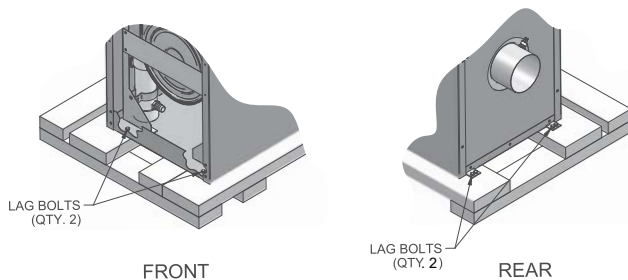

### Install flue pipe assembly *(reference FIG. 2-2 for flue pipe assembly)*

The outdoor boiler is shipped with all the necessary vent components. All components must be installed prior to operation. Basic installation steps are as follows:

1. Locate all venting components from the installation kit and carton.
2. Before connecting the flue pipe sections or components, verify the gasket is seated evenly inside the groove in the female end of the elbow and flue adapter.
3. Remove the kit provided screws from the air cover and use them to install the wall strap.
4. Insert the elbow into the flue adapter.

#### CAUTION

Do not use grease or other lubricant on the vent seals. Only water may be used for this purpose. Grease or other lubricant can make the seal brittle or it can result in tears in the surface of the seal, this will result in flue gas leakage.

**Figure 2-2** Install Flue Pipe Assembly

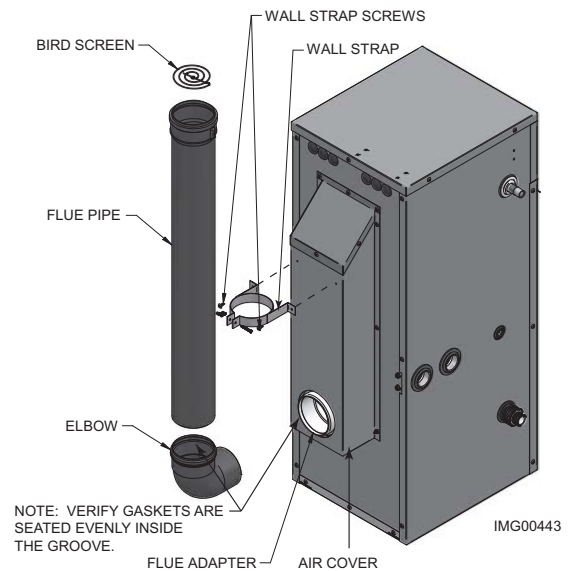

5. Slide the vent pipe through the wall strap and insert it into the elbow.
6. Install the bird screen into the top of the flue pipe.

### Gas conversions

#### WARNING

For a boiler already installed, you must turn off gas supply, turn off power and allow boiler to cool before proceeding. You must also completely test the boiler after conversion to verify performance as described under Start-up, Section 7 of this manual. Failure to comply could result in severe personal injury, death, or substantial property damage.

You must install a propane orifice to operate the outdoor boiler on propane gas. Verify when installing that the orifice size marking matches boiler size (Table 2A).

1. Remove the top and front access covers from the unit (tools required for removal).
2. Remove the three screws securing the gas valve to the venturi (FIG. 2-3).
3. Locate the propane orifice disk from the conversion kit bag. Verify that the stamping on the orifice disk matches the boiler size (see Table 2A). Place the orifice into the black rubber grommet in the side of the gas valve and secure in the valve (FIG. 2-3).
4. Reposition the gas valve against the venturi and replace the screws (FIG. 2-3) securing the valve to the venturi.

## 2 Prepare boiler *(continued)*

5. After installation is complete, attach the propane conversion label (in the conversion kit bag) next to the boiler rating plate. Attach the LP caution label (in the conversion kit bag) to the left side of the unit in the lower left corner.
6. Replace the top and front access covers.

**Table 2A LP Conversion Table**

LP Conversion Table	
Model	LP Orifice Stamping
151	150
211	210 / W150
286	285

**⚠ WARNING**

After converting to LP, check combustion per the Start-up procedure in Section 7 of this manual. Failure to check and verify combustion could result in severe personal injury, death, or substantial property damage.

**Figure 2-3 Installing Propane Orifice**

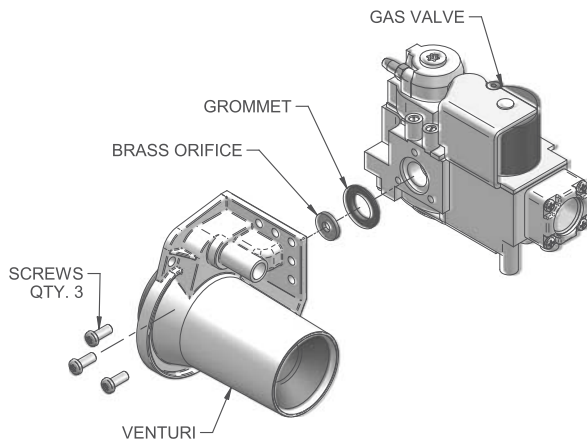

### Leveling the boiler

1. Set the boiler in place and check level.
  - a) Adjust legs if necessary to level boiler, see FIG. 2-4 below.

**Figure 2-4 Leveling Legs on the Boiler**

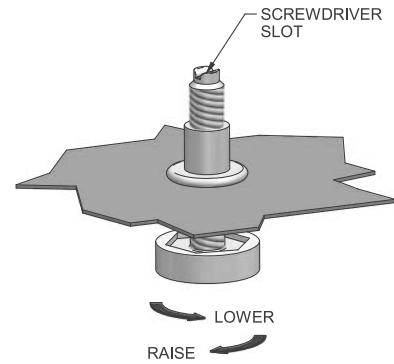

## 3 Hydronic piping

### System water piping methods

The outdoor boiler is designed to function in a closed loop pressurized system not less than 12 psi. A temperature and pressure gauge is included to monitor system pressure and outlet temperature and should be located on the boiler outlet. It is important to note that the boiler has a minimal amount of pressure drop and must be figured in when sizing the circulators. Each boiler installation must have an air elimination device, which will remove air from the system. Install the boiler so the gas ignition system components are protected from water (dripping, spraying, etc.) during appliance operation for basic service of circulator replacement, valves, and others.

Observe a minimum of 1/4 inch (6 mm) clearance around all un-insulated hot water pipes when openings around the pipes are not protected by non-combustible materials.

### Low water cutoff device

On a boiler installed above radiation level, some states and local codes require a low water cutoff device at the time of installation.

### Chilled water system

If the boiler supplies hot water to heating coils in air handler units, flow control valves or other devices must be installed to prevent gravity circulation of heater water in the coils during the cooling cycle. A chilled water medium must be piped in parallel with the heater.

### Freeze protection, heat exchanger

Freeze protection for new or existing systems must use glycol that is specially formulated for this purpose. This includes inhibitors, which prevent the glycol from attacking the metallic system components. Make certain to check that the system fluid is correct for the glycol concentration and inhibitor level. The system should be tested at least once a year and as recommended by the producer of the glycol solution. Allowance should be made for the expansion of the glycol solution in the system piping.

#### **WARNING**

Use only inhibited propylene glycol solutions, which are specifically formulated for hydronic systems. Ethylene glycol is toxic and can attack gaskets and seals used in hydronic systems.

### General piping information

Basic steps are listed in this section along with illustrations on the following pages (FIG.'s 3-4 thru 3-10), which will guide you through the installation of the outdoor boiler (reference FIG.'s 3-2A and 3-2B).

1. Connect the system return marked "Inlet".
2. Connect the system supply marked "Outlet".
3. Install purge and balance valve or shutoff valve and drain on system return to purge air out of each zone.
4. Install a backflow preventer on the cold feed make-up water line.
5. Install a pressure reducing valve on the cold feed make-up water line, (15 psi nominal). Check temperature and pressure gauge (shipped separately), which should read a minimum pressure of 12 psi.
6. Install a circulator as shown on the piping diagrams in this section. Make sure the circulator is properly sized for the system and friction loss.
7. Consult the factory for a pump and/or pump cover. If a field-supplied pump is used, install per the manufacturer's specifications in regard to indoor or outdoor location. An outdoor rated pump is recommended.
8. Install an expansion tank on the system supply. Consult the tank manufacturer's instruction for specific information relating to tank installation. Size the expansion tank for the required system volume and capacity.
9. Install an air elimination device on the system supply.
10. Install a drain valve at the lowest point of the system. **Note:** The boiler cannot be drained completely of water without purging the unit with an air pressure of 15 psi.
11. This appliance is supplied with a relief valve sized in accordance with ASME Boiler and Pressure Vessel Code, Section IV ("Heating Boilers"). Pipe the discharge of the safety relief valve to prevent injury in the event of pressure relief. Provide piping that is the same size as the safety relief valve outlet. Never block the outlet of the safety relief valve.

### 3 Hydronic piping *(continued)*

#### ⚠ WARNING

The relief valve, tee and any necessary fittings are shipped in the install kit with the boiler and are to be field installed (FIG. 3-1).

\*See the piping illustrations included in this section, FIG.'s 3-4 thru 3-10 for suggested guidelines in piping the outdoor boiler with either zone valves or circulator pumps.

#### NOTICE

\*Please note that these illustrations are meant to show system piping concept only, the installer is responsible for all equipment and detailing required by local codes.

#### CAUTION

The outdoor boiler is capable of servicing multiple temperature loop systems. It is the responsibility of the installer to protect the loops with lower temperature requirements from higher temperatures that may be required by other loops.

#### Relief valve and temperature and pressure gauge installation

Basic steps are listed below to guide you through the installation of the relief valve and the temperature and pressure (T & P) gauge provided with the unit.

1. Install the tee with the 3/4 inch fitting positioned vertically and on the top as shown in FIG. 3-1.
2. Install the relief valve into the 3/4 inch fitting of the tee installed in Step 1 (FIG. 3-1).
3. Install a field provided 5 inch long nipple and tee with the fitting positioned vertically on the top on the downstream side of the relief valve (see FIG. 3-1).
4. Install the temperature and pressure gauge provided with the unit into the top fitting of the tee (a bushing may be necessary) installed in Step 3 (FIG. 3-1).

**Figure 3-1 Relief Valve / T & P Installation**

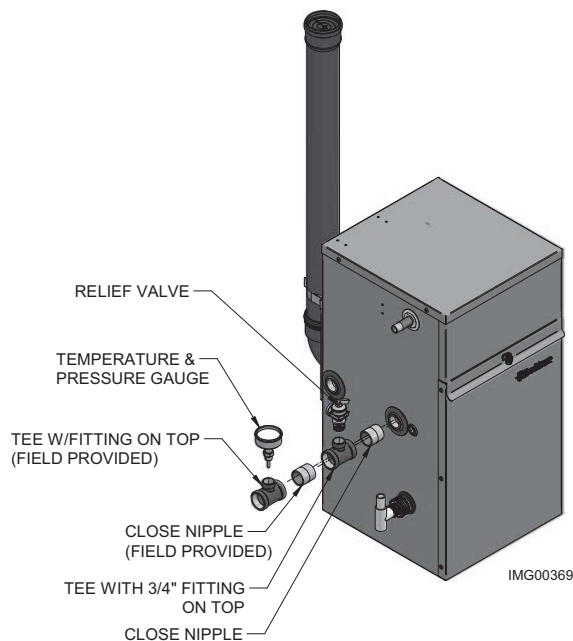

#### Near boiler piping components

##### 1. Boiler system piping:

Boiler system piping MUST be sized per the pipe requirements listed in Table 3A. Reducing the pipe size can restrict the flow rate through the boiler, causing inadvertent high limit shutdowns and poor system performance. Flow rates are based on 20 feet of piping, 4 - 90° elbows, and 2 - fully ported ball valves.

##### 2. Boiler system pump w/pump cover:

A Grundfos UPS26-99F pump and pump cover will be provided by the factory (for standard altitude models) as the boiler circulation pump based on 20 feet of piping, 4 - 90° elbows, and 2 - fully ported ball valves.

Outdoor boilers are capable of controlling a variable speed boiler circulator. Variable speed circulators MUST be sized to meet the specified minimum flow requirements listed in FIG. 3-3 on page 15 at full speed.

##### 3. Domestic hot water circulating pump:

Field supplied. The pump MUST be sized to meet the specified minimum flow requirements listed in FIG. 3-3. Consult the indirect water heater operating guide to determine flow characteristics for the selected product used.

##### 4. Boiler isolation valves:

Field supplied. Full port ball valves are required. Failure to use full port ball valves could result in a restricted flow rate through the boiler.

##### 5. Check valves:

Field supplied. Check valves are recommended for installation as shown in FIG.'s 3-4 thru 3-10. Failure to install check valves could result in a reverse flow condition during pump(s) off cycle.

##### 6. Domestic indirect hot water isolation valves:

Field supplied. Full port ball valves are required. Failure to use full port ball valves could result in a restricted flow rate through the boiler.

##### 7. Anti-scald mixing valve:

Field supplied. An anti-scald mixing valve is recommended when storing domestic hot water above 115°F.

##### 8. Unions:

Field supplied. Recommended for unit serviceability.

##### 9. Temperature and pressure gauge:

Factory supplied. The temperature and pressure gauge is shipped loose. It is the responsibility of the contractor to install the temperature and pressure gauge on the boiler water outlet.

##### 10. Pressure relief valve:

Factory supplied. The pressure relief valve is sized to ASME specifications.

##### 11. Boiler purge valve:

Field supplied. The boiler purge valve is used to remove entrapped air from the heat exchanger during start-up.

### 3 Hydronic piping

#### 12. System temperature sensor:

Lochinvar supplies a system temperature sensor. The sensor is to be installed in the heating loop downstream from the boiler hot water piping and heating loop junction. Typically the sensor will be located far enough downstream to sense system diluted water temperature.

#### 13. Indirect water heaters:

The outdoor boiler may be piped to an indirect water heater to heat domestic hot water with the space heat transfer medium. As depicted on pages 17 through 23 there are two options when utilizing an indirect water heater.

- The space heating piping will branch off to flow the space heat transfer medium through a single wall heat exchanger coil inside the indirect water heater.
- The indirect water heater is connected to the system supply piping. A pump controlled by the outdoor boiler's control will regulate the flow of water through the indirect water heater. The indirect water heater's temperature will be regulated by the outdoor boiler's control.

The outdoor boiler is pre-configured to control the operation of the DHW pump with Domestic Hot Water Prioritization programming. The DHW programming is designed to control and balance the space heating demand by switching between DHW and space heating.

#### Near boiler piping connections

Lochinvar offers the Squire which is a series of indirect water heaters. The Squire features a stainless steel vessel with a single wall stainless steel heat exchanger.

#### CAUTION

It is up to the installer to ensure the minimum system flow is not less than the minimum boiler flow at any time.

#### WARNING

The National Standard Plumbing Code and the Uniform Plumbing Code limit the pressure of the heat transfer fluid to less than the minimum working pressure of the potable water system up to 30 psi maximum. Also, the heat transfer fluid must be water or other non-toxic fluid having a toxicity of Class 1, as listed in Clinical Toxicology of Commercial Products, 5<sup>th</sup> Edition.

#### 14. Y-Strainer:

Field supplied. A Y-strainer or equivalent multipurpose strainer is recommended at the inlet of the heat exchanger to remove system particles from older hydronic systems and protect newer systems.

#### Circulator sizing

The outdoor boiler heat exchanger does have a pressure drop, which must be considered in your system design. Refer to the graph in FIG. 3-3 for pressure drop through the outdoor boiler heat exchanger.

Figure 3-2A Near Boiler Piping w/Y-Strainer

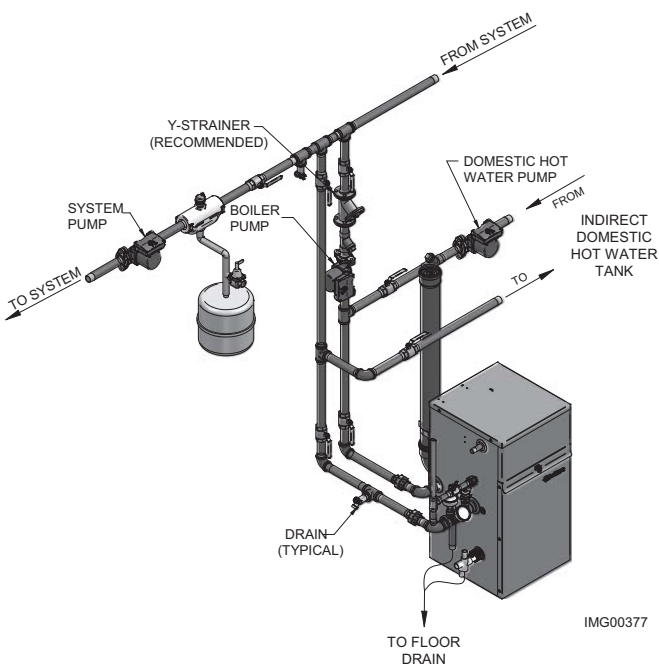
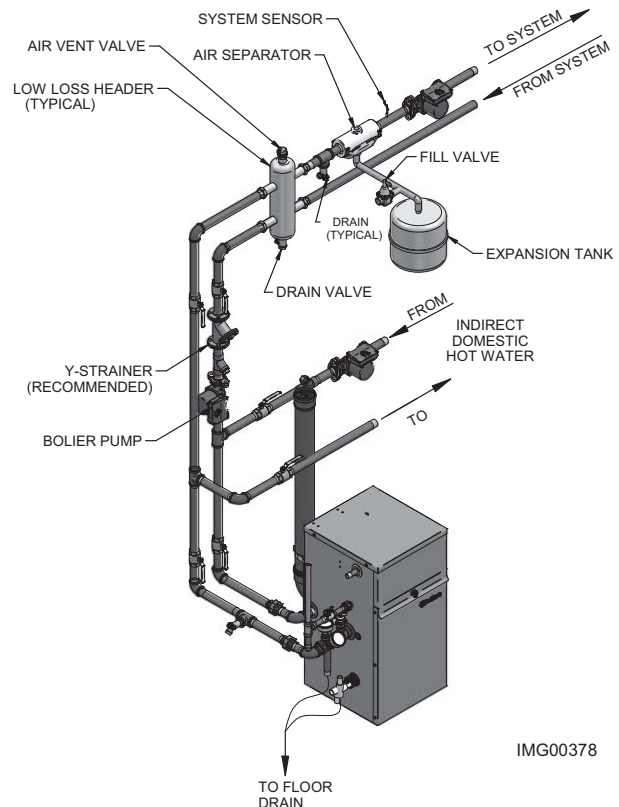
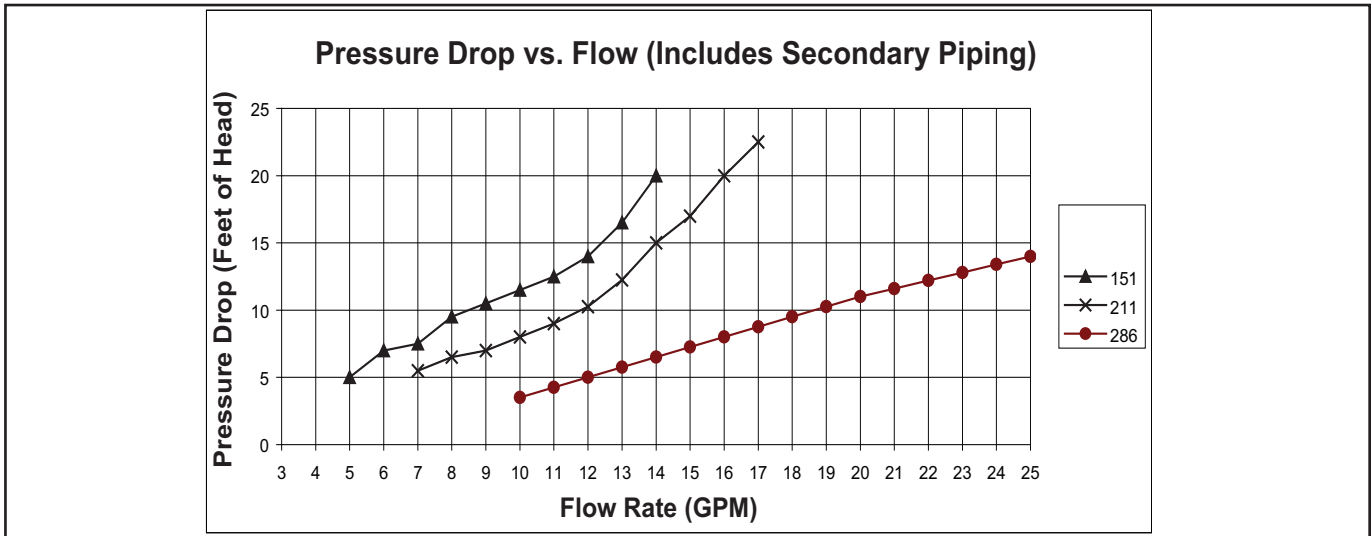

Figure 3-2B Near Boiler Piping w/Low Loss Header



### 3 Hydronic piping *(continued)*

**Figure 3-3 Pressure Drop vs. Flow**

**Table 3A Circulator Recommendations for Temperature Rise Applications\_20°, 25°, and 35°**

20°F Temperature Rise Applications							
Model	GPM	FT/HD	Minimum Pipe Size	Pump			
				Grundfos	TACO	B & G	Armstrong
151	14	20	1"	<b>UPS26-99F</b>	0011	NRF-36	E7
211	20	29	1"	UPS32-160	1400-50	PL-55	E9*
286	27	15	1-1/4"	UPS32-80	1400-20	PL-36	E11

**\*NOTICE** These pumps are only slightly above 20° rise flows, but are the closest available. To reach a 20° rise or less, an upsized pump will be required.

25°F Temperature Rise Applications							
Model	GPM	FT/HD	Minimum Pipe Size	Pump			
				Grundfos	TACO	B & G	Armstrong
151	11	13	1"	<b>UPS26-99F</b>	0014	NRF-36	E7
211	16	19	1"	<b>UPS26-99F</b>	0013	NRF-36	E7
286	21	12	1-1/4"	<b>UPS26-99F</b>	0011	NRF-36	E7

35°F Temperature Rise Applications							
Model	GPM	FT/HD	Minimum Pipe Size	Pump			
				Grundfos	TACO	B & G	Armstrong
151	8	10	1"	<i>UPS15-58FC</i>	008/0010	NRF-36	Astro-30
211	11	9	1"	<i>UPS15-58FC</i>	0010	NRF-36	Astro-50
286	15	7	1-1/4"	UP26-64F	008/0010	NRF-36	E7

**NOTICE** Pumps listed in bold type are provided by the factory as the boiler circulation pump on standard altitude models.

**NOTICE** Pumps listed in italicized type are provided by the factory as the boiler circulation pump on high altitude models.

**NOTICE** The temperature rise provided by a pump/model combination will decrease by 3% per 1000 feet of elevation.

## 3 Hydronic piping

### Variable speed pump option

**Table 3B** Recommended Variable Speed Pumps

Minimum Temperature Rise*			
Model	Pump		
	Grundfos UP26-96 FC/VS	TACO 0013 IFC VS	Wilo Stratos 1.25 3 x 30
151	21	20	19
211	27	25	24
286	27	24	22

\*The minimum temperature rise is derived from the chart in FIG. 3-3 with the firing rate and pump speed at 100% as shown in the table above.

The shaded regions of pump coverage are only available for applications with 230V (60 Hz) supply voltage, all others are to be 115V. (A field supplied relay is required to connect the 230V pump listed in the shaded area in Table 3B to the boiler high voltage terminal strip.)

#### Variable speed pump setup

Before operation, ensure the following:

- Pump is set for an input signal of 0 - 10Vdc by the dip switches on the pump control
- Pump is set for external signal control (if applicable)
- Pump is set for linear output (if applicable)
- If pump does not come equipped with a 0 - 10 Vdc input option, an optional module will be required from the vendor

**NOTICE**

Pump sizing and flow requirements are based on 20 feet of piping, 4 - 90° elbows, and 2 - fully ported ball valves.

**NOTICE**

It is required that near boiler piping systems utilize the *Primary/Secondary* configuration shown in FIG. 3-10 only. The use of other near boiler piping configurations could result in improper building and system flow rates leading to inadvertent boiler high limit shutdowns and poor system performance.

#### SMART SYSTEM / Multi-temperature loop control option

The outdoor boiler is capable of producing up to three (3) set point temperatures to meet different space heating demands. When using more than one temperature demand it is necessary to protect the lower temperature loop from overheating. To help aid with this protection, Lochinvar offers the Multi-Temperature Loop Control Board Kit (RLY30086).



### 3 Hydronic piping *(continued)*

**Figure 3-4** Single Boiler - Single Temperature Zoned with Circulators

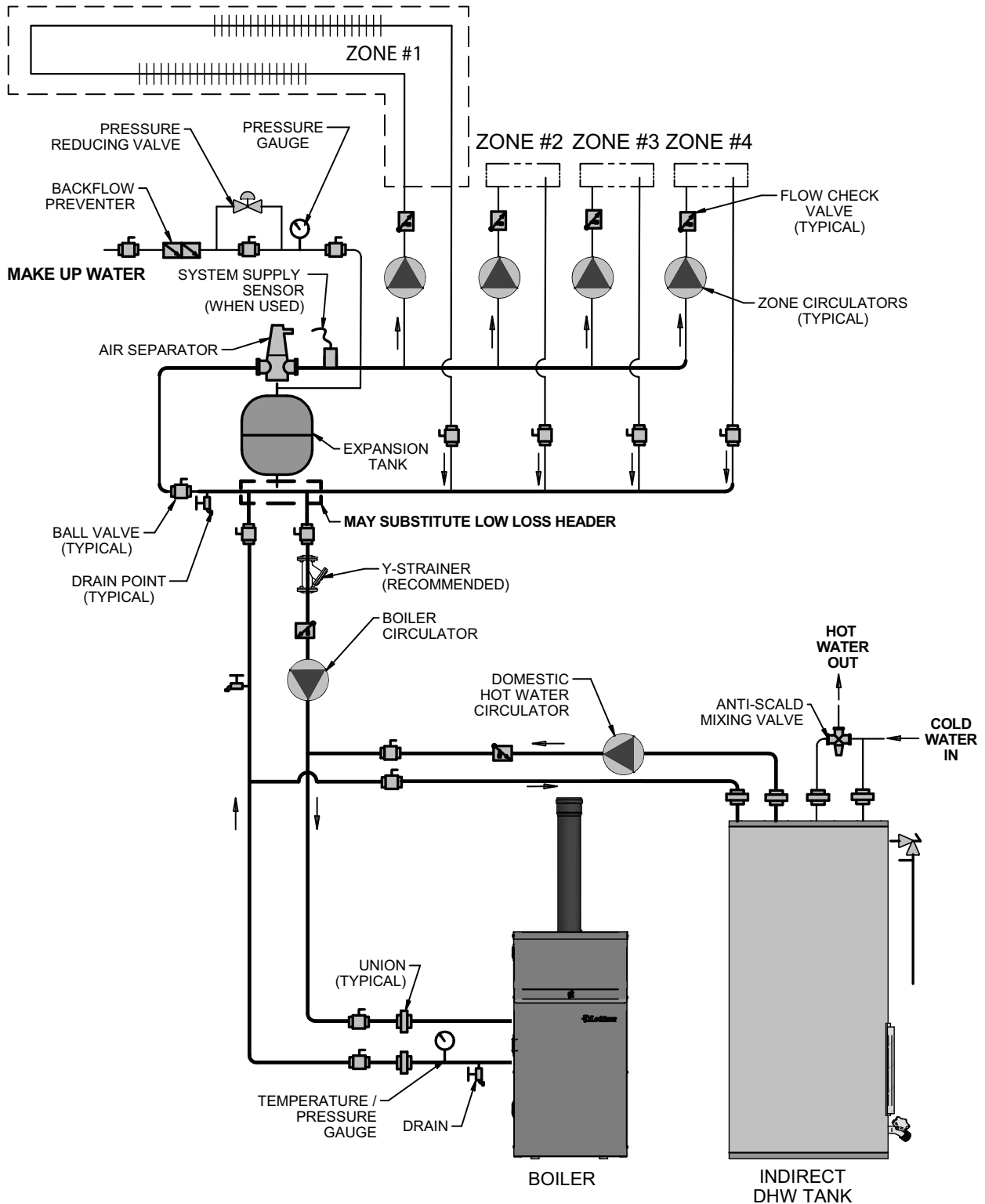

IMG00370

**NOTICE**

Please note that these illustrations are meant to show system piping concept only, the installer is responsible for all equipment and detailing required by local codes.

Indoor tank shown for illustration purposes.

### 3 Hydronic piping

Figure 3-5 Multiple Boilers - Single Temperature Zoned with Circulators

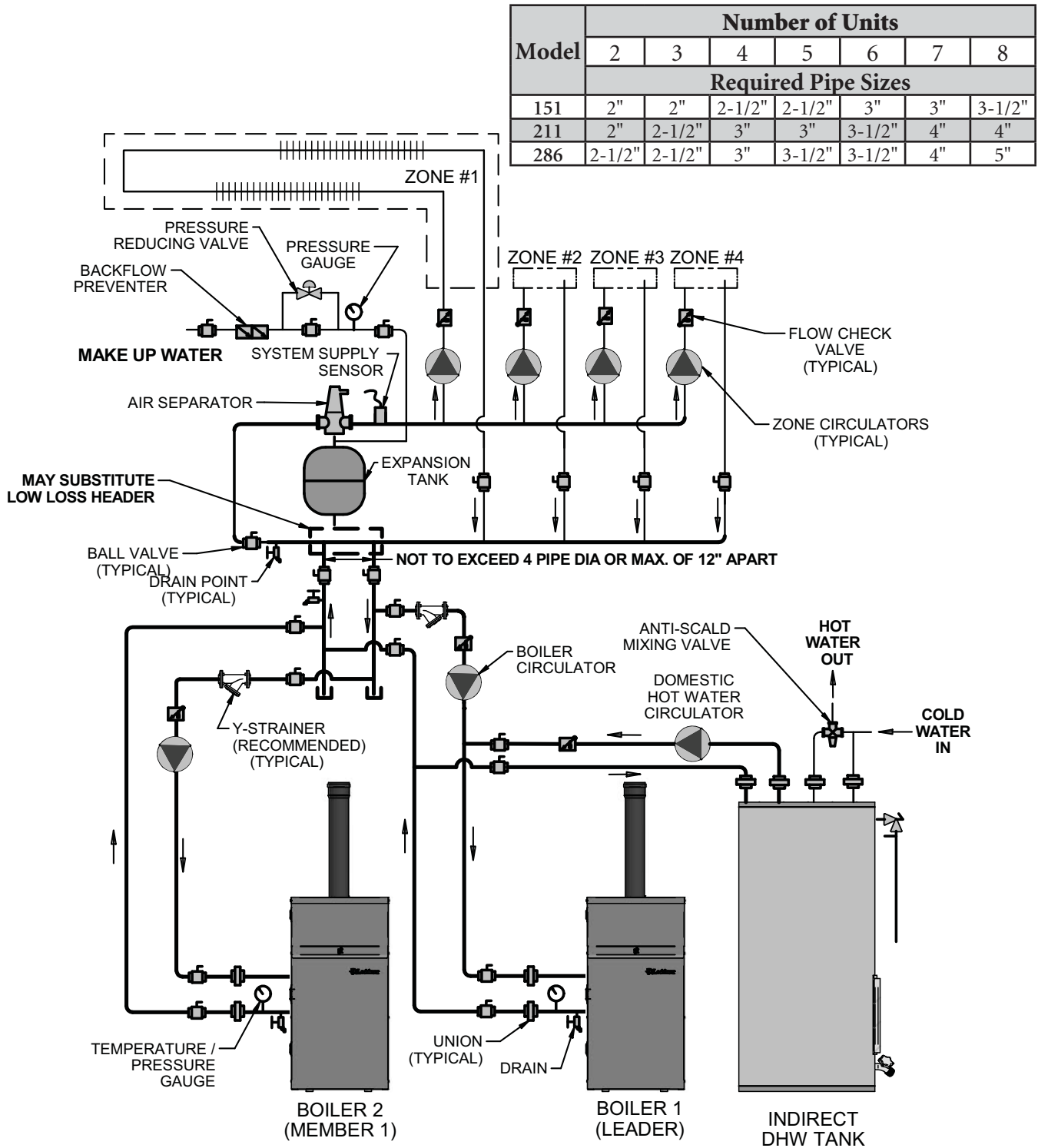

IMG00371

**NOTICE**

Please note that these illustrations are meant to show system piping concept only, the installer is responsible for all equipment and detailing required by local codes.

Indoor tank shown for illustration purposes.

### 3 Hydronic piping *(continued)*

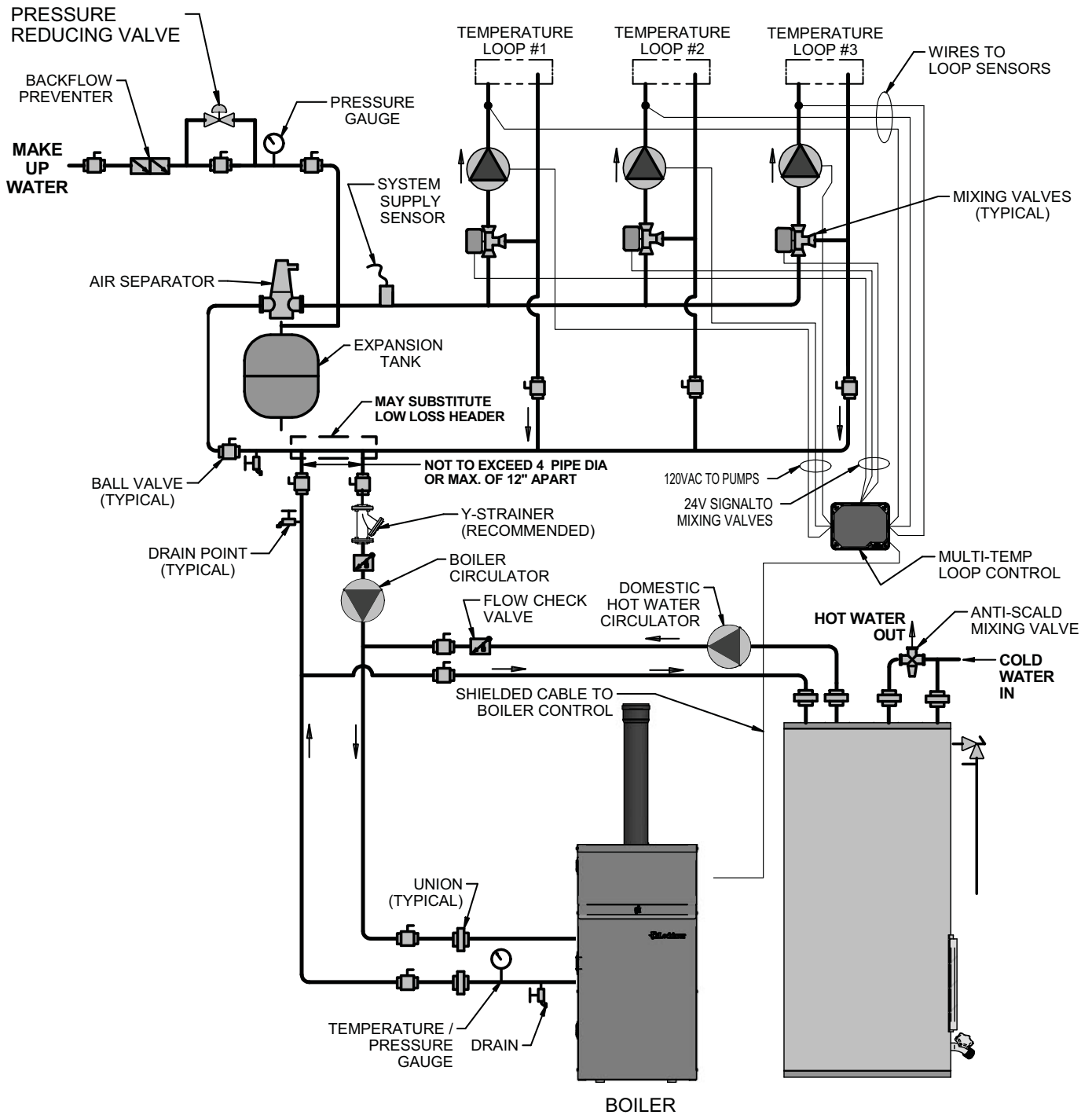
**Figure 3-6 Single Boiler - Multiple Temperatures**

IMG00372

**CAUTION**

Mixing valves are required for the protection of low temperature loops.

**NOTICE**

Please note that these illustrations are meant to show system piping concept only, the installer is responsible for all equipment and detailing required by local codes.

Indoor tank shown for illustration purposes.

# 3 Hydronic piping

**Figure 3-7 Multiple Boilers - Multiple Temperatures**

Model	Number of Units							
	2	3	4	5	6	7	8	
	Required Pipe Sizes							
151	2"	2"	2-1/2"	2-1/2"	3"	3"	3-1/2"	
211	2"	2-1/2"	3"	3"	3-1/2"	4"	4"	
286	2-1/2"	2-1/2"	3"	3-1/2"	3-1/2"	4"	5"	

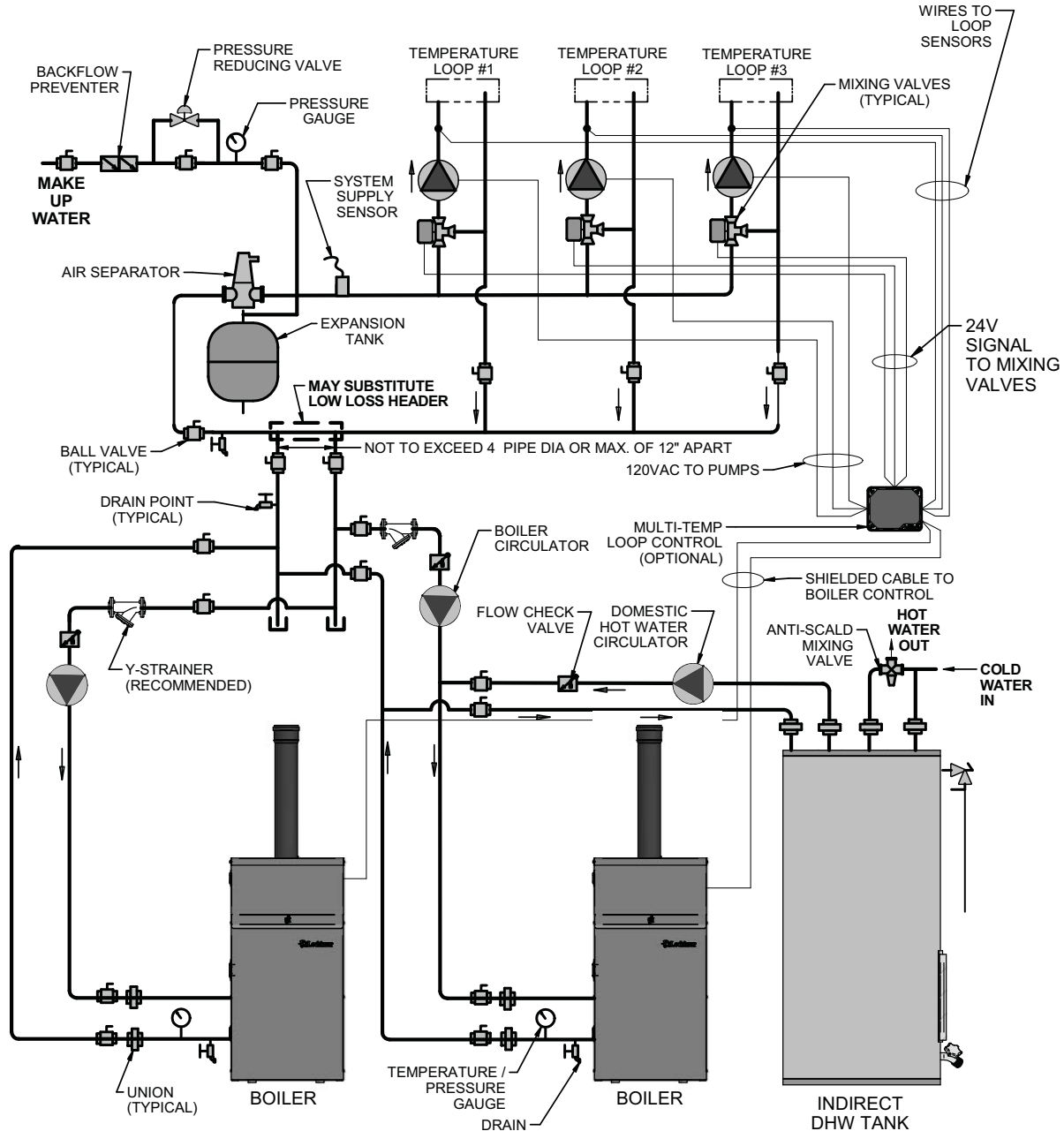

IMG00373

**CAUTION**

Mixing valves are required for the protection of low temperature loops.

**NOTICE**

Please note that these illustrations are meant to show system piping concept only, the installer is responsible for all equipment and detailing required by local codes.

Indoor tank shown for illustration purposes.

### 3 Hydronic piping *(continued)*

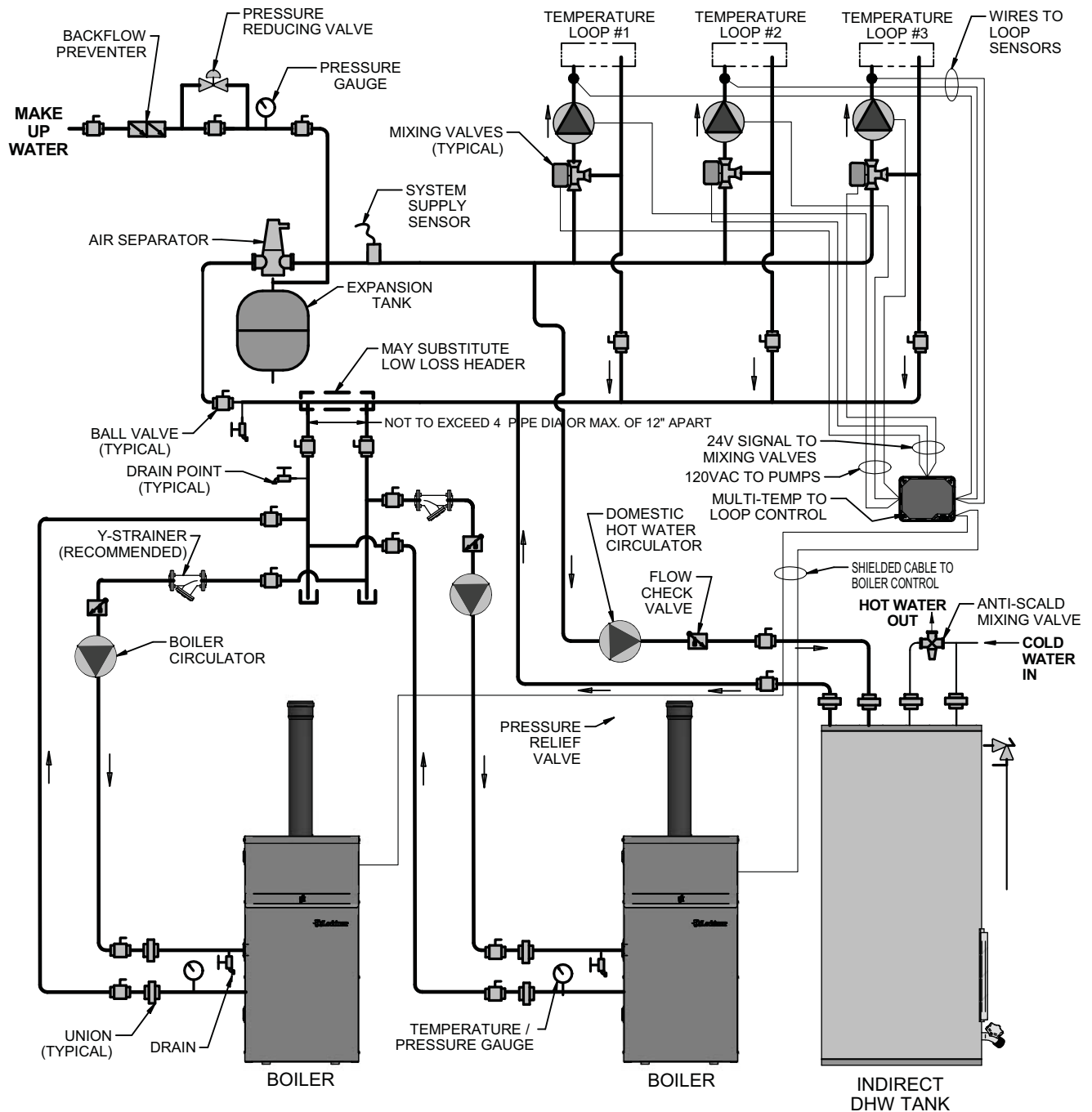
**Figure 3-8** Single Boiler - Multiple Temperatures with DHW Piped as a Zone

IMG00374

**CAUTION**

Mixing valves are required for the protection of low temperature loops.

**NOTICE**

Please note that these illustrations are meant to show system piping concept only, the installer is responsible for all equipment and detailing required by local codes.

Indoor tank shown for illustration purposes.

**NOTICE**

Please note that the installer is responsible for ensuring DHW prioritization when piped as a zone.

Indoor tank shown for illustration purposes.

### 3 Hydronic piping

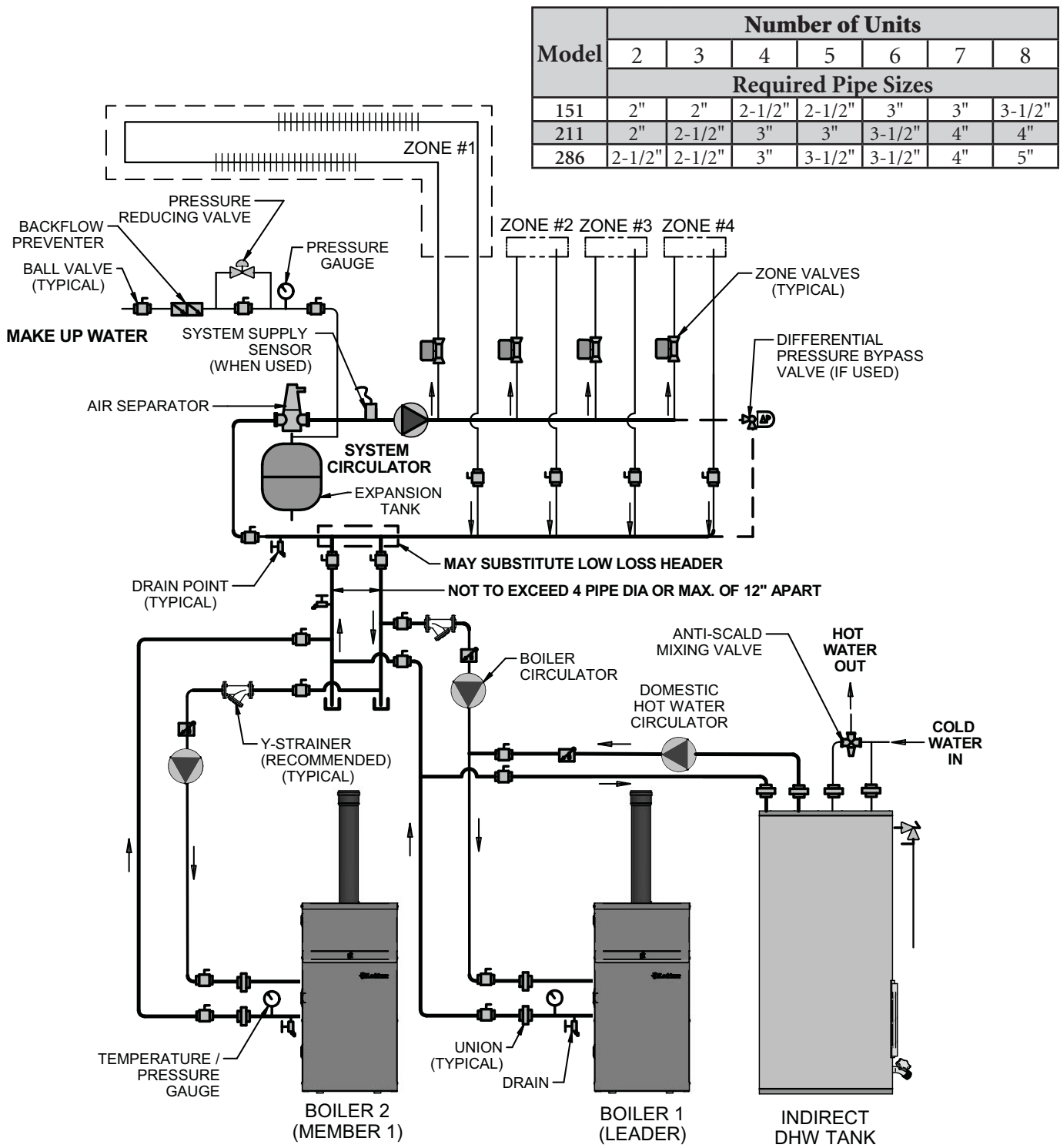
**Figure 3-9 Multiple Boilers - Single Temperature Zoned with Valves**

IMG00375

**NOTICE**

Please note that these illustrations are meant to show system piping concept only, the installer is responsible for all equipment and detailing required by local codes.

Indoor tank shown for illustration purposes.

### 3 Hydronic piping *(continued)*

**Figure 3-10 Multiple Boilers - Non-Zoned Primary/Secondary Piping**

Model	Number of Units						
	2	3	4	5	6	7	8
	Required Pipe Sizes						
151	2"	2"	2-1/2"	2-1/2"	3"	3"	3-1/2"
211	2"	2-1/2"	3"	3"	3-1/2"	4"	4"
286	2-1/2"	2-1/2"	3"	3-1/2"	3-1/2"	4"	5"

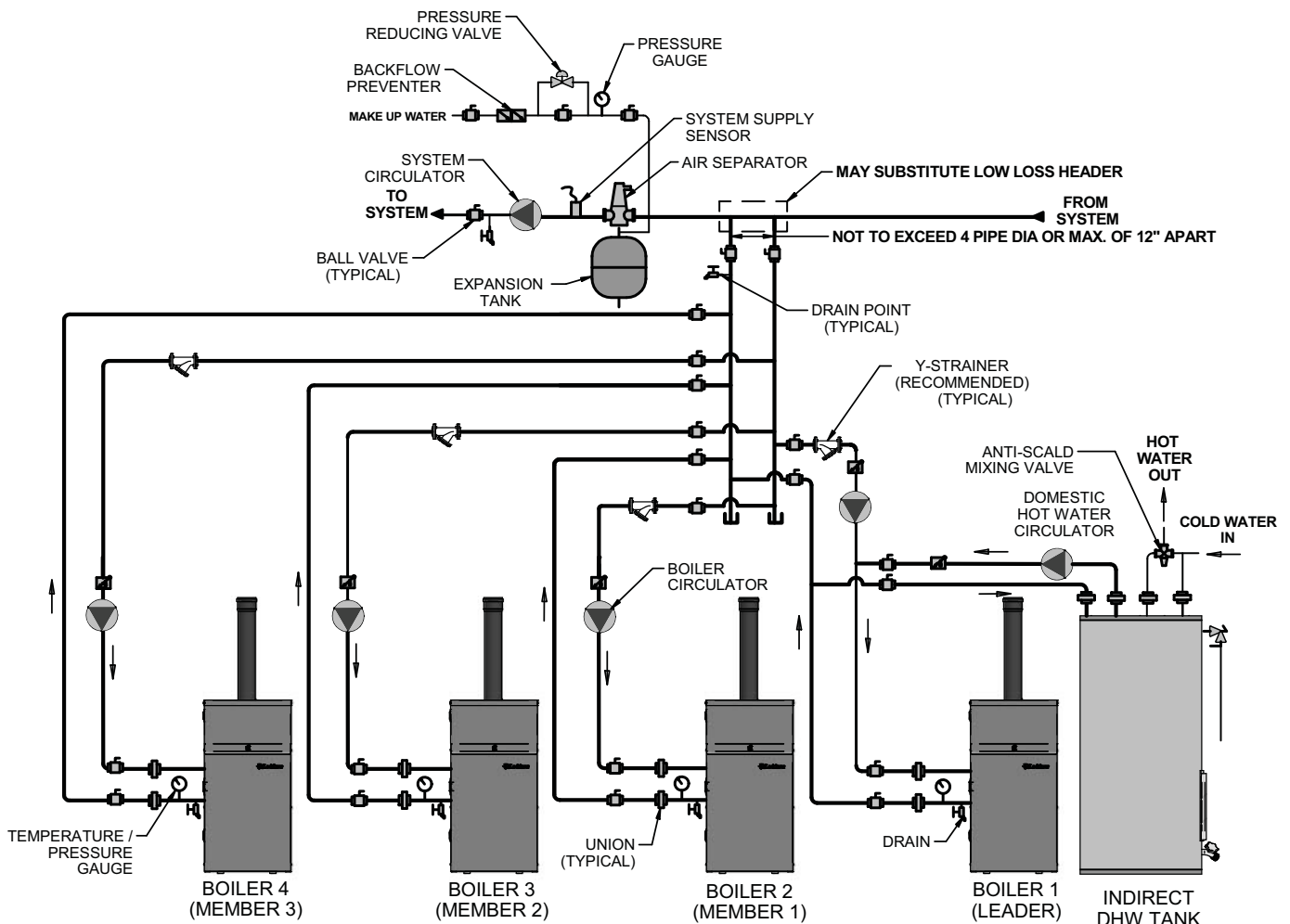

IMG00376

**NOTICE**

Please note that these illustrations are meant to show system piping concept only, the installer is responsible for all equipment and detailing required by local codes.

Indoor tank shown for illustration purposes.

## 4 Gas connections

### Connecting gas supply piping

1. Remove the top access cover and refer to FIG. 4-1 to pipe gas to the boiler.
  - a. Install ground joint union for servicing, when required.
  - b. Install a manual shutoff valve in the gas supply piping outside boiler jacket when required by local codes or utility requirements.
2. Install sediment trap / drip leg.

**Figure 4-1 Gas Supply Piping**

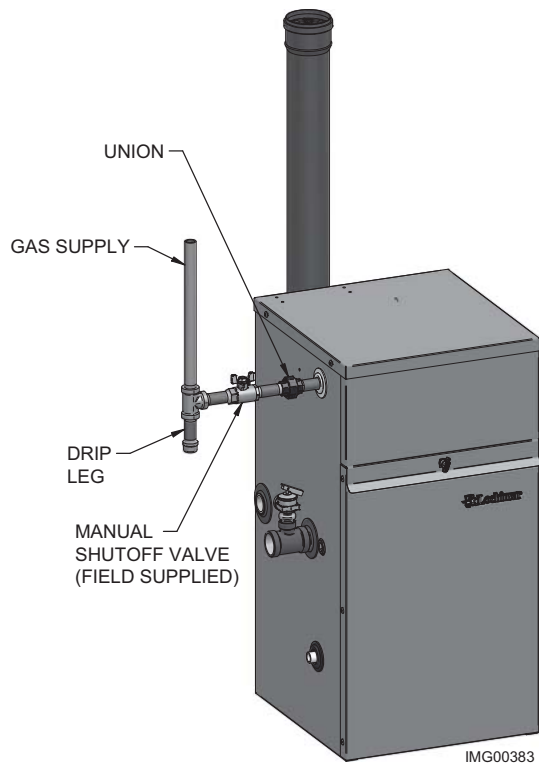

3. Support piping with hangers, not by the boiler or its accessories.

**⚠ WARNING**

The gas valve and blower will not support the weight of the piping. Do not attempt to support the weight of the piping with the boiler or its accessories. Failure to comply could result in severe personal injury, death, or substantial property damage.

4. Purge all air from the gas supply piping.
5. Before placing the boiler in operation, check the boiler and its gas connection for leaks.
  - a. The appliance must be disconnected from the gas supply piping system during any pressure testing of that system at a test pressure in excess of 1/2 PSIG (3.5 kPa).
  - b. The appliance must be isolated from the gas supply piping system by closing a manual shutoff valve during any pressure testing of the gas supply piping system at test pressures equal to or less than 1/2 PSIG (3.5 kPa).
  - c. The appliance and its gas connection must be leak tested before placing it in operation.

**⚠ WARNING**

Do not check for gas leaks with an open flame – use the bubble test. Failure to use the bubble test or check for gas leaks can cause severe personal injury, death, or substantial property damage.

6. Use pipe sealing compound compatible with propane gases. Apply sparingly only to male threads of the pipe joints so that pipe dope does not block gas flow.

**⚠ WARNING**

Failure to apply pipe sealing compound as detailed in this manual can result in severe personal injury, death, or substantial property damage.

**⚠ WARNING**

Outdoor boilers are typically shipped ready to fire on natural gas. Check boiler rating plate to determine which fuel the boiler is set for. If set to natural gas, it may be converted to LP by installing an orifice (see page 11). In order to operate on LP gas, an orifice **MUST BE** installed. Failure to comply could result in severe personal injury, death, or substantial property damage.



## 4 Gas connections *(continued)*

**⚠ WARNING** Use two wrenches when tightening gas piping at boiler (FIG. 4-2), using one wrench to prevent the boiler gas line connection from turning. Failure to support the boiler gas connection pipe to prevent it from turning could damage gas line components.

**Figure 4-2 Inlet Pipe with Backup Wrench**

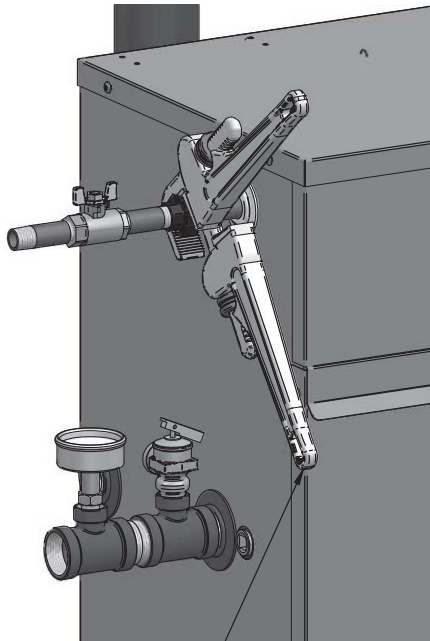

USE BACKUP WRENCH  
TO PREVENT PIPE FROM  
ROTATING

IMG00384

**NOTICE** Maximum inlet gas pressure must not exceed the value specified. Minimum value listed is for the purposes of input adjustment.

### Natural gas:

#### Pipe sizing for natural gas

1. Refer to Table 4A for pipe length and diameter. Based on rated boiler input (divide by 1,000 to obtain cubic feet per hour).
  - a. Table 4A is only for natural gas with specific gravity 0.60 inches, with a pressure drop through the gas piping of 0.5 inches w.c.
  - b. For additional gas pipe sizing information, refer to ANSI Z223.1 (or B149.1 for Canadian installations).

#### Natural gas supply pressure requirements

1. Pressure required at the gas valve inlet pressure port:
  - Maximum 14 inches w.c. with no flow (lockup) or with boiler on.
  - Minimum 4 inches w.c. with gas flowing (verify during boiler startup).
2. Install 100% lockup gas pressure regulator in supply line if inlet pressure can exceed 14 inches w.c. at any time. Adjust lockup regulator for 14 inches w.c. maximum.

### Propane Gas:

**⚠ WARNING**

Outdoor boilers are typically shipped ready to fire on natural gas. Check boiler rating plate to determine which fuel the boiler is set for. If set to natural gas, it may be converted to LP by installing an orifice (see page 11). In order to operate on LP gas, an orifice **MUST BE** installed. Failure to comply could result in severe personal injury, death, or substantial property damage.

#### Pipe sizing for propane gas

1. Contact gas supplier to size pipes, tanks, and 100% lockup gas pressure regulator.

#### Propane Supply Pressure Requirements

1. Adjust propane supply regulator provided by the gas supplier for 14 inches w.c. maximum pressure.
2. Pressure required at gas valve inlet pressure port:
  - Maximum 14 inches w.c. with no flow (lockup) or with boiler on.
  - Minimum 8 inches w.c. with gas flowing (verify during boiler startup).

**⚠ WARNING**

Ensure that the high gas pressure regulator is at least 6 - 10 feet upstream of the appliance.

## 4 Gas connections

**Table 4A** Natural Gas Pipe Size Chart

Nominal Iron Pipe Size (Inches)	Single Unit Natural Gas Pipe Capacity Chart Length of Pipe in Straight Feet for 1/2 PSI													
	10	20	30	40	50	60	70	80	90	100	125	150	175	200
1/2	175	120	97	82	N/A	N/A	N/A	N/A	N/A	N/A	N/A	N/A	N/A	N/A
3/4	369	256	205	174	155	141	128	121	113	106	95	86	79	74
1	697	477	384	328	292	267	246	236	210	200	179	164	149	138
1-1/4	1400	974	789	677	595	543	502	472	441	410	369	333	308	287
1-1/2	2150	1500	1210	1020	923	830	769	707	666	636	564	513	472	441
2	4100	2820	2260	1950	1720	1560	1440	1330	1250	1180	1100	974	871	820
2-1/2	6460	4460	3610	3100	2720	2460	2310	2100	2000	1900	1700	1540	1400	1300
3	11200	7900	6400	5400	4870	4410	4000	3800	3540	3330	3000	2720	2500	2340
4	23500	16100	13100	11100	10000	9000	8300	7690	7380	6870	6150	5640	5130	4720

**⚠ WARNING**

Outdoor boilers are typically shipped ready to fire on natural gas. Check boiler rating plate to determine which fuel the boiler is set for. If set to natural gas, it may be converted to LP by installing an orifice (see page 11). In order to operate on LP gas, an orifice **MUST BE** installed. Failure to comply could result in severe personal injury, death, or substantial property damage.

### Check inlet gas supply

**NOTICE**

CSA or UL listed flexible gas connections are acceptable, but you must exercise caution to ensure that the line has adequate capacity to allow your boiler to fire at full rate. Consult with local codes for proper installation or service procedures.

**⚠ WARNING**

DO NOT adjust gas valve outlet pressure. The gas valve is factory-set for the correct outlet pressure. This setting is suitable for natural gas and propane, requiring no field adjustment. Attempting to alter the gas valve outlet pressure could result in damage to the valve, causing potential severe personal injury, death, or substantial property damage.

The gas piping must be sized for the proper flow and length of pipe, to avoid excessive pressure drop. Both the gas meter and the gas regulator must be properly sized for the total gas load.

If you experience a pressure drop greater than 1 inch w.c., the meter, regulator, or gas line is undersized or in need of service. Perform the steps below when checking inlet gas supply:

1. Turn the main power switch to the "OFF" position.
2. Shut off gas supply at the manual gas valve in the gas piping to the appliance.

3. Loosen the set screw one (1) full turn from inside the pressure tap on top of the gas valve. Place the tubing of the manometer over the tap once the set screw is loosened as shown in FIG. 4-3.
4. Slowly turn on the gas supply at the field installed manual gas valve.
5. Turn the power switch to the "ON" position.
6. Adjust the temperature set point on the control panel of the SMART SYSTEM control module to call for heat.
7. Observe the gas supply pressure as the burner fires at 100% of rated input. Percent of burner input will be displayed on the control panel.
8. Ensure inlet pressure is within specified range. Minimum and maximum gas supply pressures are specified in this section of the manual.
9. If gas supply pressure is within normal range and no adjustments are needed, proceed on to Step 11.
10. If the gas pressure is out of range, contact the gas utility, gas supplier, qualified installer or service agency to determine the necessary steps to provide proper gas pressure to the control.
11. Turn the power switch to the "OFF" position.
12. Shut off the gas supply at the manual gas valve in the gas piping to the appliance.
13. Remove the manometer from the pressure tap on top of the gas valve. Re-tighten the set screw inside the pressure tap.

## 4 Gas connections *(continued)*

**⚠ WARNING** When re-tightening the set screw, be sure to tighten securely to prevent gas leaks.

Do not check for gas leaks with an open flame -- use the bubble test. Failure to use the bubble test or check for gas leaks can cause severe personal injury, death, or substantial property damage.

14. Turn on the gas supply at the manual gas valve.
15. Turn the power switch to the "ON" position.
16. Adjust the temperature set point on the control panel of the SMART SYSTEM control module to the desired water temperature so the appliance will call for heat.
17. Check burner performance by cycling the system while you observe burner response. The burner should ignite promptly. Flame pattern should be stable. Turn system off and allow burner to cool, then cycle burner again to ensure proper ignition and flame characteristics.

**Figure 4-3 Inlet Gas Supply Check**

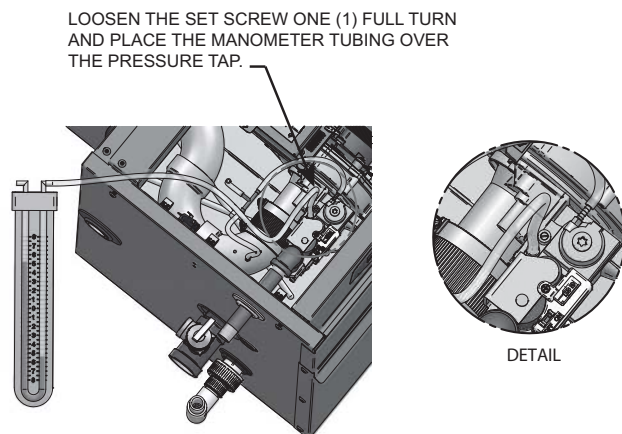

### Gas Pressure

The gas pressure must remain between 4 inches w.c. (natural), 8 inches w.c. (LP) minimum and 14 inches w.c. (natural and LP) maximum during stand-by (static) mode and while in operating (dynamic) mode. If an in-line regulator is used, it must be a minimum of 10 feet from the outdoor boiler. It is very important that the gas line is properly purged by the gas supplier or utility company. Failure to properly purge the lines or improper line sizing, will result in ignition failure.

The problem is especially noticeable in NEW LP installations and also in empty tank situations. This can also occur when a utility company shuts off service to an area to provide maintenance to their lines.

### Gas valve replacement

The gas valve **MUST NOT** be replaced with a conventional gas valve under any circumstances. As an additional safety feature, this gas valve has a flanged connection to the venturi and blower.

**⚠ WARNING** Failure to follow all precautions could result in fire, explosion, or death!

**⚠ WARNING** DO NOT adjust gas valve outlet pressure. The gas valve is factory-set for the correct outlet pressure. This setting is suitable for natural gas and propane, requiring no field adjustment. Attempting to alter the gas valve outlet pressure could result in damage to the valve, causing potential severe personal injury, death, or substantial property damage.

# 5 Field wiring

**WARNING** ELECTRICAL SHOCK HAZARD – For your safety, turn off electrical power supply before making any electrical connections to avoid possible electric shock hazard. Failure to do so can cause severe personal injury or death.

**NOTICE** Wiring must be N.E.C. Class 1. If original wiring as supplied with boiler must be replaced, use only type 105°C wire or equivalent.

Boiler must be electrically grounded as required by National Electrical Code ANSI/NFPA 70 – latest edition.

All wiring exterior to the appliance must be enclosed in approved conduit.

**NOTICE** In accordance with Section 303 of the 2007 Energy Act, this boiler is equipped with a feature that saves energy by reducing the boiler water temperature as the heating load decreases. This feature is equipped with an override, which is provided primarily to permit the use of an external energy management system that serves the same function. This override **MUST NOT** be used unless at least one of the following conditions is true:

1. An external energy management system is installed that reduces the boiler water temperature as the heating load decreases.
2. This boiler is not used for any space heating.
3. This boiler is part of a modular or multiple boiler system having a total input of 300,000 Btu/hr or greater.
4. This boiler is equipped with a tankless coil.

**CAUTION** Label all wires prior to disconnection when servicing controls. Wiring errors can cause improper and dangerous operation.

## Installation must comply with:

1. National Electrical Code and any other national, state, provincial, or local codes, or regulations.

## Line voltage connections

1. Connect 120 vac power wiring to the line voltage terminal strip in the junction box, as shown in FIG. 5-1.
2. Provide and install a fused disconnect or service switch (15 amp recommended) as required by the code (see FIG. 5-1).
3. The boiler pump is shipped loose. Wire the boiler pump as shown in FIG. 5-1.
4. When connecting a domestic hot water (DHW) pump, connect the wiring to the line voltage terminal strip as shown in FIG. 5-1.
5. To activate a system pump, wire as shown in FIG. 5-1. If the motor is larger than 1/8 hp or 1.8 amps, you must isolate with a relay.

## Low voltage connections

1. Route all low voltage wires through the knockouts in the rear of the boiler, as shown in FIG. 5-2.
2. Connect low voltage wiring to low voltage connection board as shown in FIG. 5-3 on page 31 of this manual and the boiler wiring diagram.

**Figure 5-1 Line Voltage Field Wiring Connections**

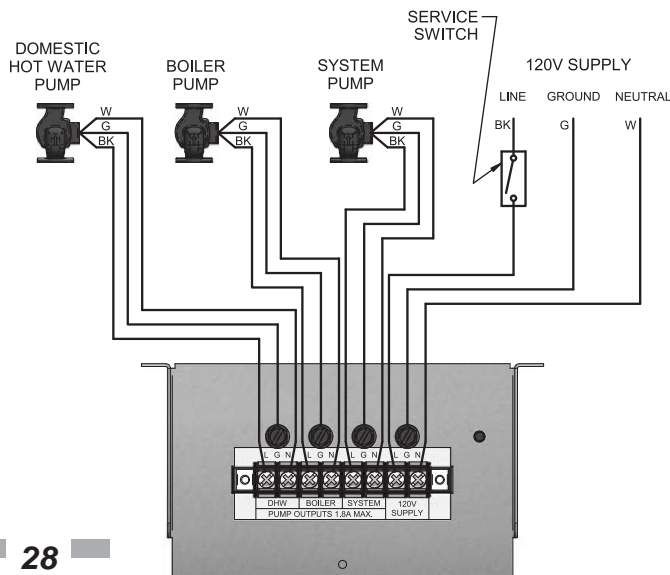

**Figure 5-2 Routing Field Wiring**

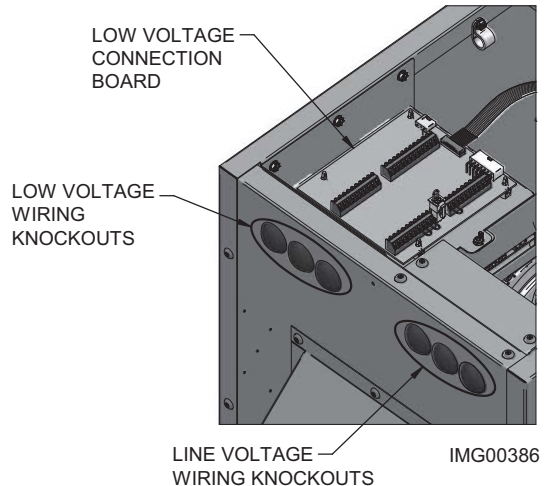

## 5 Field wiring *(continued)*

### Thermostat

1. Connect the room thermostats or end switches (isolated contact only) to Heat/Loop Demand 1, 2, or 3, as shown in FIG. 5-3.
2. Install the thermostat on the inside wall away from influences of drafts, hot or cold water pipes, lighting fixtures, television, sunlight, or fireplaces.
3. Thermostat anticipator (if applicable):
  - a. If connected directly to boiler, set for 0.1 amps.
  - b. If connected to relays or other devices, set to match total electrical power requirements of connected devices. See device manufacturers' specifications and thermostat instructions for details.

### Outdoor temperature sensor

In the absence of an external energy management system, an outdoor temperature sensor must be used.

1. Mount the sensor on an exterior wall, shielded from direct sunlight or flow of heat or cooling from other sources.
2. Route sensor wires through a knockout at the rear of the boiler (see FIG. 5-2).
3. Connect the outdoor temperature sensor (FIG. 5-3) to the outdoor sensor terminals on the connection board to enable outdoor reset operation of the outdoor boiler.

### DHW thermostat

Connect storage indirect water heater (DHW) thermostat (FIG. 5-3) to the DHW thermostat terminals on the connection board. If a tank sensor is connected (see DHW Tank Sensor below) the tank thermostat is ignored.

### DHW tank sensor

1. By installing a tank sensor, the SMART SYSTEM control can perform the tank thermostat function. The SMART SYSTEM control automatically detects the presence of this sensor and generates a DHW call for heat when the tank temperature drops 6°F (3°C) below the tank set point and finishes the call for heat when the tank temperature reaches the tank set point.
2. The tank sensor included with the Lochinvar Squire Indirect DHW tank (TST20015) is the only sensor suitable for use with the SMART SYSTEM control. Connect the sensor leads to the Tank Sensor terminals on the Low Voltage Connection Board (FIG. 5-3).

#### **WARNING**

Failure to use the correct sensor may result in the tank temperature being either above or below the set point.

3. If the TST20015 is not compatible with the indirect tank, a tank thermostat can be used to control the boiler. The tank thermostat should be installed per the manufacturers instructions and wired to the DHW Thermostat terminals on the Low Voltage Connection Board.

### High gas pressure switch

If a switch is provided to detect excessive gas pressure, remove the jumper wire from the terminals on the connection board, and then connect them to its normally closed contacts (FIG. 5-3).

### Low gas pressure switch

1. If a switch is provided to detect low gas pressure, remove the jumper wire from the terminals on the connection board and connect them to its normally open contacts (FIG. 5-3).
2. If both a high and low gas pressure switch is used, connect their respective contacts in series, and connect them to the terminals on the connection board (FIG. 5-3).

### Variable speed system pump

If a variable speed pump is used in the primary loop, and a 0-10V signal is available from the pump speed control, this signal can be used by the SMART SYSTEM control to anticipate changes in the building heat load. By connecting this 0 - 10V signal to the 0 - 10V SYS PUMP IN terminals, the boiler (or cascade) can modulate up and down as the primary flow increases and decreases.

### Boiler pump speed output

This 0 - 10V output is available to control the speed of a variable speed boiler pump. The SMART SYSTEM control will vary the speed of this pump in order to maintain a minimum  $\Delta T$  across the heat exchanger, as well as prevent high limit lockouts when the flow in the primary loop is extremely low. Connect this output to the 0 - 10V input on the boiler pump speed control.

### Rate output

This output provides a 0 - 10V signal that is proportional to the firing rate of the boiler. This may be used by a BMS system to monitor the actual rate of the boiler.

### ModBus

When the optional ModBus interface module is installed, the RS-485 ModBus cable is connected to these terminals. Use shielded, 2-wire twisted pair cable. If desired, the shield can be connected to ground by installing a jumper wire between terminals 1 and 3 on connector X5 on the optional ModBus interface module.

## 5 Field wiring

### Flow switch

1. A flow switch is used to guarantee flow through the boiler before allowing it to fire. The flow switch must be installed at the boiler outlet.
2. Remove the jumper wire from these terminals, and connect these terminals to the normally open contacts on the flow switch (FIG. 5-3).

### System supply sensor

1. By installing the system supply sensor into the supply of the primary loop, the temperature of the primary supply can be controlled. The SMART SYSTEM control automatically detects the presence of this sensor, and controls the boiler firing rate to maintain the system supply temperature to the set point (if the outlet sensor control is currently selected). If it is desired to control the system return temperature, then program the SMART SYSTEM control to use the inlet sensor as the controlling sensor. See the Outdoor Knight Boiler Service Manual for instructions on how to use the inlet sensor as the controlling sensor. When the inlet sensor is programmed as the controlling sensor, it is vital that the SYSTEM SUPPLY sensor be installed. **DO NOT INSTALL THE SYSTEM SUPPLY SENSOR INTO THE SYSTEM RETURN.**
2. The TST2032 sensor provided with the boiler must be used for the system sensor.
3. Connect these terminals to the system supply sensor (FIG. 5-3).

### Boiler management system

The United States Energy Policy and Conservation Act requires residential heating boilers with inputs less than 300,000 Btu/hr be equipped with a control that automatically adjusts boiler water temperature in relation to heat demand. An external control may be connected to control the firing rate or the set point of the boiler provided that either an external energy management system is installed that reduces the boiler water temperature as the heating load decreases, the boiler is not used for any space heating, or the boiler is part of a modular or multiple boiler system having a total input of 300,000 Btu/hr or greater.

1. An external control may be connected to control either the firing rate or the set point of the boiler. If the external control uses a set of contacts to enable the boiler, connect the contacts to the Heat/Loop Demand 1 terminals. Otherwise, the SMART SYSTEM control will be enabled by the 0-10V signal.
2. Make sure the (-) terminal is connected to the (-) or common output terminal of the external control, and the 0 - 10 Vdc terminal is connected to the 0 - 10 Vdc terminal of the external control. Make sure the (-) voltage is not below ground.

### Runtime contacts

The SMART SYSTEM control closes a set of dry contacts whenever the burner is running. This is typically used by Building Management Systems to verify that the boiler is responding to a call for heat.

### Alarm contacts

The SMART SYSTEM control closes another set of contacts whenever the boiler is locked out or the power is turned off. This can be used to turn on an alarm, or signal a Building Management System that the boiler is down.

### Wiring of the cascade

When wiring the boilers for Cascade operation, select one boiler as the Leader boiler. The remaining boilers will be designated as Members. See page 38 “Configuration of the Cascade” for a detailed explanation of this procedure.

Connect the system supply sensor and outdoor air sensor (if used) to the Leader boiler. For the Cascade system to work properly the system supply sensor must be installed. The location of the system supply sensor should be downstream of the boiler connections in the main system loop (FIG.'s 3-5, 3-7, and 3-9). The system supply sensor should be wired to the Low Voltage Connection Board at the terminals marked for the system sensor (see FIG. 5-3). The Leader control will use the water temperature at the system supply sensor to control the operation of the Cascade.

The outdoor air sensor should be wired to the Low Voltage Connection Board at the terminals marked for the outdoor air sensor (FIG. 5-3). The Leader control will calculate the water temperature set point based on the programmed reset curve parameters.

If a Thermostat, Zone Control enable output, or Building Management System enable output is available, it should be wired to the Low Voltage Connection Board on the Leader boiler at the terminals marked for one of the heat/loop demands 1-3 (FIG. 5-3). If the boilers are to run continuously, connect a jumper wire between the R and W terminals for the heat/loop demand input. This will initiate a call for heat on the Cascade.

Communication between the Leader boiler and the Member boilers is accomplished by using shielded, 2-wire twisted pair communication cable. Connect one of the twisted pair wires to Cascade terminal A on each of the Low Voltage Connection boards, and the other wire of the twisted pair to Cascade terminal B on each of the Low Voltage Connection Boards. Connect the shield wires to one of the shield terminals on the Low Voltage Connection Boards (FIG. 5-3). If more than two boilers are on the Cascade, daisy chain the wiring from the Cascade terminals on the second boiler to the Cascade terminals on the third boiler, then from the third to the fourth, and so on. The connections between boilers can be made in any order, regardless of the addresses of the boilers. Try to keep each cable as short as possible.

# 5 Field wiring *(continued)*

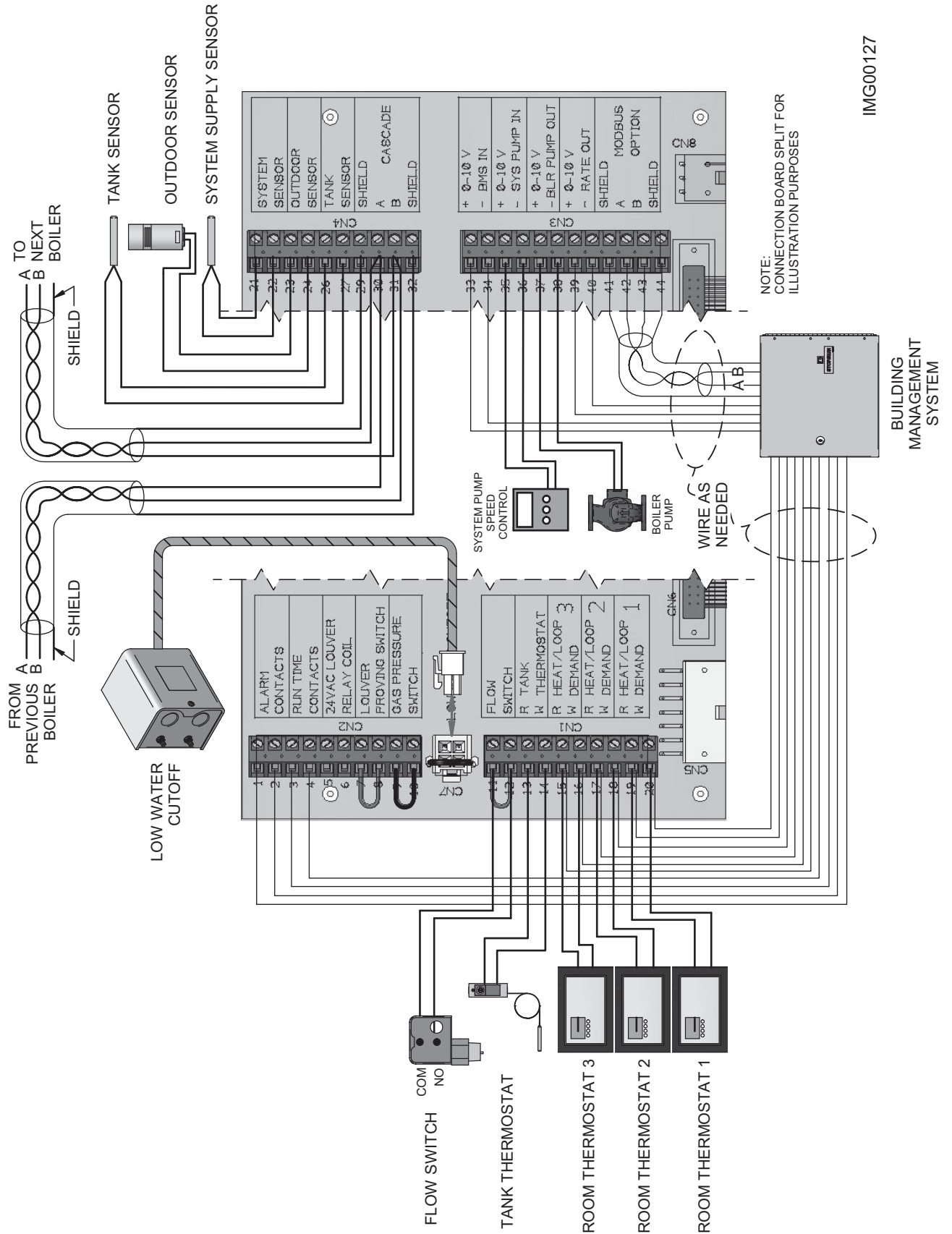
**Figure 5-3 Low Voltage Field Wiring Connections**

IMG00127

## 6 Condensate disposal

### Condensate drain

1. This boiler is a high efficiency appliance that produces condensate.
2. The side of the boiler has a 1/2 inch PVC union for connection of a 1/2 inch PVC pipe (FIG. 6-1).
3. Slope condensate tubing down and away from the boiler into a drain or condensate neutralizing filter. Condensate from the outdoor boiler will be slightly acidic (typically with a pH from 3 to 5). Install a neutralizing filter if required by local codes.

A Neutralizer Kit (FIG. 6-1) is available from the factory (Kit 3087).

4. Install the 1/2 inch PVC tee assembly (shipped with the unit) as shown in FIG. 6-1.
5. Leave the top of the 1/2 inch tee OPEN. This is needed as a vacuum break.
6. Do not expose condensate line to freezing temperatures. Precautions should be taken to protect the condensate management and disposal system during extended periods of outdoor temperatures below 32°F.
7. Use only plastic tubing or piping as a condensate drain line (FIG. 6-1).

#### NOTICE

Use materials approved by the authority having jurisdiction. In the absence of other authority, PVC and CPVC pipe must comply with ASTM D1785 or D2845. Cement and primer must comply with ASME D2564 or F493.

#### NOTICE

To allow for proper drainage on large horizontal runs, a second line vent may be required and tubing size may need to increase to 1 inch.

The condensate line must remain unobstructed, allowing free flow of condensate. If condensate is allowed to freeze in the line or if the line is obstructed in any other manner, condensate can exit from the boiler tee, resulting in potential water damage to property.

8. A condensate removal pump is required if the boiler is below the drain. When installing a condensate pump, select one approved for use with condensing boilers and furnaces. The pump should have an overflow switch to prevent property damage from condensate spillage. The switch should be wired in series with the blocked drain switch inside the boiler (see FIG. 7-1 on page 34).

**Figure 6-1** Condensate Disposal

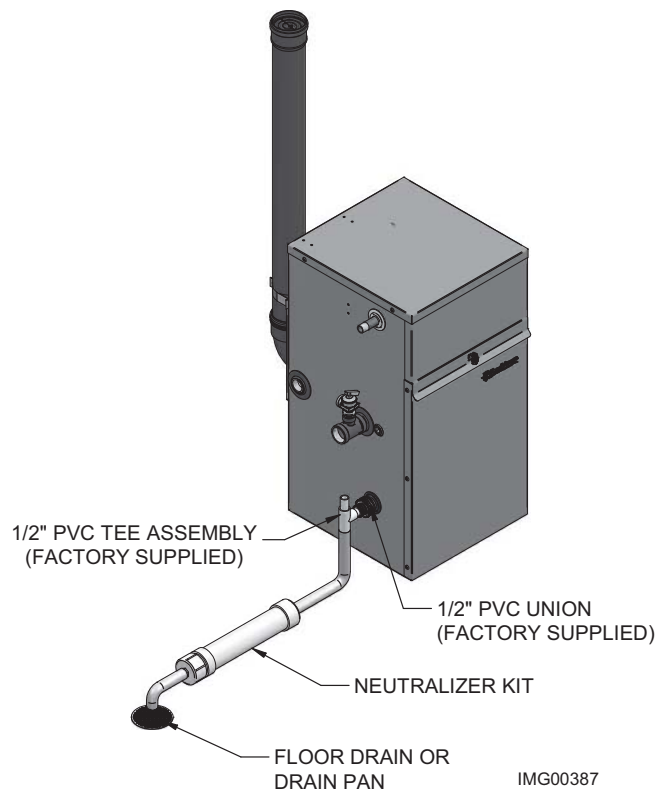



# 7 Start-up

## Check/control water chemistry

### ⚠ CAUTION

Do not use petroleum-based cleaning or sealing compounds in the boiler system. Damage to elastomer seals and gaskets in the system could occur, resulting in substantial property damage.

### Hardness less than 7 grains

1. Consult local water treatment companies for hard water areas (above 7 grains hardness).

### Chlorine concentration less than 200 ppm

1. Do not fill boiler or operate with water containing chlorine in excess of 200 ppm.
2. Filling with chlorinated fresh water should be acceptable since drinking water chlorine levels are much lower.
3. Do not use the boiler to directly heat swimming pool or spa water.

### Test/replace freeze protection fluid

1. For systems using freeze protection fluids, follow fluid manufacturer's instructions.
2. Freeze protection fluid must be replaced periodically due to degradation of inhibitors over time. Follow all fluid manufacturer's instructions.

### Freeze protection (when used)

1. Determine freeze protection fluid quantity using system water content, following fluid manufacturer's instructions. Boiler water content is listed on page 7. Remember to include expansion tank water content.
2. Local codes may require a backflow preventer or actual disconnect from city water supply.
3. When using freeze protection fluid with automatic fill, install a water meter to monitor water makeup. Freeze protection fluid may leak before the water begins to leak, causing concentration to drop, reducing the freeze protection level.
4. The freeze protection set points may be lowered when freeze protection fluid is used (see the Outdoor Knight Service Manual).

### Fill and test water system

1. Fill system only after ensuring the water meets the requirements of this manual.
2. Close manual and automatic air vents and boiler drain valve.

3. Fill to correct system pressure. Correct pressure will vary with each application.
  - a. The minimum cold water fill pressure for a residential system is 12 psi.
  - b. Pressure will rise when boiler is turned on and system water temperature increases.
4. At initial fill and during boiler startup and testing, check system thoroughly for any leaks. Repair all leaks before proceeding further.

### ⚠ WARNING

Eliminate all system leaks. Continual fresh makeup water will reduce boiler life. Minerals can build up in the heat exchanger, reducing heat transfer, overheating the heat exchanger, and causing heat exchanger failure.

### Purge air from water system

1. Purge air from system:
  - a. Connect a hose to the purge valve (see purge/drain valves, in piping diagrams on pages 17 through 23). Route the hose to an area where water can drain and be seen.
  - b. Close the boiler or system isolation valve between the purge valve and fill connection to the system.
  - c. Close zone isolation valves.
  - d. Open quick-fill valve on cold water makeup line.
  - e. Open purge valve.
  - f. One zone at a time, open the isolation valves. Allow water to run through the zone, pushing out the air. Run until no noticeable air flow is present. Close the zone isolation valves and proceed with the next zone. Follow this procedure until all zones are purged.
  - g. Close the quick-fill water valve and purge valve and remove the hose. Open all isolation valves. Watch that system pressure rises to correct cold-fill pressure.
  - h. After the system has operated for a while, eliminate any residual air by using the manual air vents located throughout the system.
  - i. If purge valves are not installed in the system, open the manual air vents in the system one at a time, beginning with the lowest floor. Close the vent when water squirts out. Repeat with remaining vents.
2. Open automatic air vent (diaphragm-type or bladder-type expansion tank systems only) one turn.
3. Open other vents:
  - a. Starting on the lowest floor, open air vents one at a time until water squirts out.
  - b. Repeat with remaining vents.
4. Refill to correct pressure.

# 7 Start-up

## Check for gas leaks

### ⚠ WARNING

Before starting the boiler, and during initial operation, smell near the floor and around the boiler for gas odorant or any unusual odor. Remove the top access cover and smell the interior of the boiler enclosure. Do not proceed with startup if there is any indication of a gas leak. Use an approved leak detection solution. Repair any leaks at once.

### ⚠ WARNING

DO NOT adjust gas valve outlet pressure. The gas valve is factory set for the correct outlet pressure. This setting is suitable for natural gas and propane, requiring no field adjustment. Attempting to alter the gas valve outlet pressure could result in damage to the valve, causing potential severe personal injury, death, or substantial property damage.

**Figure 7-1 Condensate Trap**

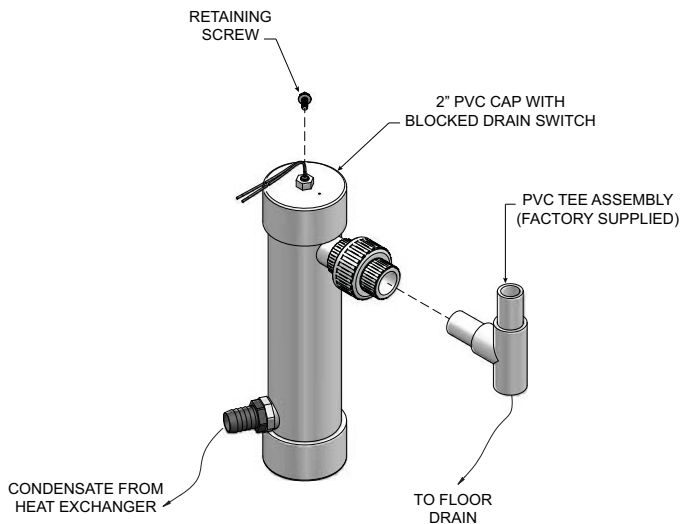

### ⚠ WARNING

Propane boilers only – Your propane supplier mixes an odorant with the propane to make its presence detectable. In some instances, the odorant can fade, and the gas may no longer have an odor. Before startup (and periodically thereafter), have the propane supplier verify the correct odorant level in the gas.

## Check thermostat circuit(s)

1. Disconnect the two external wires connected to each of the heat/loop demand terminals on the connection board.
2. Connect a voltmeter across these two incoming wires. Close each thermostat, zone valve, and relay in the external circuit one at a time and check the voltmeter reading across the incoming wires.
3. There should NEVER be a voltage reading.
4. If a voltage does occur under any condition, check and correct the external wiring. (This is a common problem when using 3-wire zone valves.)
5. Once the external thermostat circuit wiring is checked and corrected if necessary, reconnect the external thermostat circuit wires to the connection board.

## Inspect/fill condensate system

### Inspect/check condensate lines and fittings

1. Inspect the condensate drain line, condensate PVC fittings and condensate trap.

### Fill condensate trap with water

1. Remove the PVC cap retaining screw from the PVC cap (FIG. 7-1).
2. Remove the 2 inch PVC cap with the switch located at the top of the trap (FIG. 7-1).
3. Fill with fresh water until the water begins to pour out of the drain.
4. Replace the cap. Press the cap onto the trap until the cap makes contact with the drain.
5. Replace the retaining screw.

### ⚠ WARNING

The condensate trap (FIG. 7-1) must be filled with water during all times of boiler operation to avoid flue gas emission from the condensate drain line. Failure to fill the trap could result in severe personal injury or death.

## 7 Start-up *(continued)*

### Final checks before starting the boiler

- ❑ Read the Outdoor Knight Boiler Service Manual to familiarize yourself with SMART SYSTEM control module operation. Read this manual, page 36 for proper steps to start boiler.
- ❑ Verify the boiler and system are full of water and all system components are correctly set for operation.
- ❑ Verify the preparation procedures of Section 7, pages 33 and 34 have been completed.
- ❑ Fill the vent condensate trap with water (removing the retaining screw in order to remove the 2 inch PVC cap with the switch located at the top of the trap). Replace the cap. Press the cap onto the trap until the cap makes contact with the drain. Replace the retaining screw.
- ❑ Verify electrical connections are correct and securely attached.
- ❑ Verify air opening and vent opening are free of obstruction.

### Start the boiler

1. Read and follow the Operating instructions in FIG. 7-2, page 36.

### If boiler does not start correctly

1. Check for loose connections, blown fuse or service switch off?
2. Is boiler water temperature above 200°F?
3. Is thermostat set below the controlling sensor temperature?
4. Is gas turned on at meter or boiler?
5. Is incoming gas pressure less than 4 inches w.c.?

If none of the above corrects the problem, refer to the Troubleshooting Section of the Outdoor Knight Boiler Service Manual.

### Check system and boiler

#### ❑ Check water piping

1. Check system piping for leaks. If found, shut down the boiler and repair immediately. (See WARNINGS on pages 33 and 34 (startup) regarding failure to repair leaks.)
2. Vent any remaining air from the system using manual vents. Air in the system will interfere with circulation and cause heat distribution problems and noise.

#### ❑ Check gas piping

1. Check around the boiler for gas odor following the procedure on page 24 of this manual (connecting gas supply piping).

#### WARNING

If you discover evidence of any gas leak, shut down the boiler at once. Find the leak source with a bubble test and repair immediately. Do not start the boiler again until corrected. Failure to comply could result in severe personal injury, death, or substantial property damage.

#### ❑ Propane boilers – verify conversion

1. Verify propane conversion has been completed per the Propane Conversion instructions.

#### WARNING

DO NOT adjust gas valve outlet pressure. The gas valve is factory-set for the correct outlet pressure. This setting is suitable for natural gas and propane, requiring no field adjustment. Attempting to alter the gas valve outlet pressure could result in damage to the valve, causing potential severe personal injury, death, or substantial property damage.

#### WARNING

Outdoor boilers are typically shipped ready to fire on natural gas. Check boiler rating plate to determine which fuel the boiler is set for. If set to natural gas, it may be converted to LP by installing an orifice (see page 11). In order to operate on LP gas, an orifice MUST BE installed. Failure to comply could result in severe personal injury, death, or substantial property damage.

### Check flame and combustion

1. Turn the main power off to the boiler by placing the “On/Off” switch in the OFF position.
2. Remove the flue temperature sensor from the flue pipe connection. **NOTE:** Combustion measurements will be made at this point.
3. Turn the main power on to the boiler by placing the “On/Off” switch in the ON position.

# 7 Start-up

Figure 7-2 Operating Instructions

## FOR YOUR SAFETY READ BEFORE OPERATING

**WARNING:** If you do not follow these instructions exactly, a fire or explosion may result causing property damage, personal injury, or loss of life.

- A. This appliance does not have a pilot. It is equipped with an ignition device which automatically lights the burner. Do not try to light the burner by hand.
- B. BEFORE OPERATING smell all around the appliance area for gas. Be sure to smell next to the floor because some gas is heavier than air and will settle on the floor.

### WHAT TO DO IF YOU SMELL GAS

Do not try to light any appliance.

Do not touch any electric switch; do not use any phone in your building.

Immediately call your gas supplier from a neighbor's phone. Follow the gas supplier's instructions.

If you cannot reach your gas supplier, call the fire department.

- C. Use only your hand to move the gas control switch. Never use tools. If the switch will not move by hand, don't try to repair it, call a qualified service technician. Force or attempted repair may result in a fire or explosion.
- D. Do not use this appliance if any part has been under water. Immediately call a qualified service technician to inspect the appliance and to replace any part of the control system and any gas control which has been under water.

## OPERATING INSTRUCTIONS

1. **STOP!** Read the safety information above on this label.
2. Set the thermostat to lowest setting.
3. Turn off all electric power to the appliance.
4. This appliance is equipped with an ignition device which automatically lights the burner. Do not try to light the burner by hand.
5. Remove front door.
6. Move switch to the "OFF" position.
7. Wait five (5) minutes to clear out any gas. If you then smell gas, **STOP!** Follow "B" in the safety information above this label. If you don't smell gas, go to next step.
8. Move the switch to the "ON" position.
9. Install front door.
10. Turn on all electric power to appliance.
11. Set thermostat to desired setting.
12. If the appliance will not operate, follow the instructions "To Turn Off Gas To Appliance" and call your service technician or gas supplier.

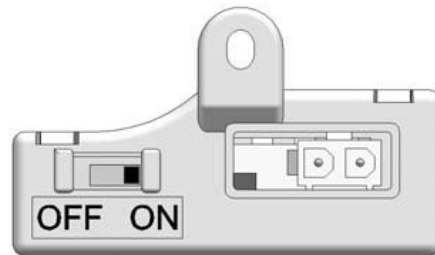

## TO TURN OFF GAS TO APPLIANCE

1. Set the thermostat to lowest setting.
2. Turn off all electric power to the appliance if service is to be performed.
3. Remove front door.
4. Move switch the "OFF" position.
5. Install front door.

## 7 Start-up *(continued)*

### Check flame and combustion *(continued)*

**NOTICE**

Please note that the brackets ([ ]) denote screen status.

4. Place the boiler into the active position by pressing the RIGHT SELECT [ON] key (FIG. 8-1, page 45).
5. Locate the pinhole button below the RESET button on the display board (FIG. 8-1). Insert a thin wire (such as a paper clip) into the hole and press the button once and hold for 5 seconds to place the boiler into Service Mode. In Service Mode the boiler will fire at ignition speed and will then modulate up to full fire.
6. Insert the probe from a combustion analyzer into the flue outlet opening.
7. Once the boiler has modulated up to full fire, measure the combustion. The values should be in the range listed in Table 7A below. The CO levels should be less than 150 ppm for a properly installed unit.

If the combustion is not within the specified range, reference the Troubleshooting Section of the Outdoor Knight Boiler Service Manual for possible causes and corrective actions.

**Table 7A Flue Products Chart**

Natural Gas		Propane	
CO <sub>2</sub>	O <sub>2</sub>	CO <sub>2</sub>	O <sub>2</sub>
8.0% - 10%	3.0% - 6.5%	9.0% - 11%	4.1% - 6.9%

8. Once the combustion analysis is complete, test the safety shutoff device by turning the manual shutoff switch to the OFF position and ensuring that the boiler shuts down and registers an alarm. Turn the manual shutoff switch to the ON position and reset the control.
9. Turn the main power off to the boiler.
10. Place the boiler back into normal operation.

### Set space heating operation

#### Determine controlling sensor

For space heating systems, the temperature control can be based on one of three sensors; the inlet, outlet, or system supply sensor. The SMART SYSTEM control is programmed at the factory to control the temperature of the outlet sensor. The control will automatically switch to the system supply sensor once it is connected. If it is desired to base the temperature control on the inlet sensor, the appropriate parameter must be changed in the control. See the Outdoor Knight Boiler Service Manual for a detailed explanation of this procedure.

#### Verify space heat circulator mode

The Space Heating Mode controls both the system pump (if connected), and the boiler pump. When the SMART SYSTEM control receives a space heating call for heat, it turns on the system pump. If the boiler is not heating an indirect DHW (Domestic Hot Water) tank, and the set point is not met, it also turns on the boiler pump. After the space heating call for heat ends, the system pump continues to run for a short period of time. The system pump can be programmed to run continuously, except during outdoor shutdown. If the boiler pump was running, it continues to run for a short period of time as well. These pump delays are factory set to 30 seconds. If different delays are desired, the appropriate parameters in the control must be changed. See the Outdoor Knight Boiler Service Manual for a detailed explanation of this procedure.

#### Adjust set point temperature(s)

**NOTICE**

Please note that the brackets ([ ]) denote screen status.

The NAVIGATION dial may be used during normal operation to adjust the space heating and tank set point temperatures.

1. From the Status Screen press the NAVIGATION dial.
2. Turn the NAVIGATION dial counterclockwise to select the appropriate set point.
3. Press the NAVIGATION dial to adjust the temperature.
4. Once the desired temperature is displayed, press the RIGHT SELECT [SAVE] key.
5. If necessary repeat Steps 3 and 4 to make adjustments to additional set points.
6. Press the RIGHT SELECT [HOME] key to upload the changes.
7. If the RIGHT SELECT [SAVE] key is not pressed, the new settings will be discarded.

# 7 Start-up

## Set domestic hot water (DHW) operation

### Verify DHW mode

There are two (2) modes of operation for DHW. In Normal Mode, when a DHW demand begins, the control will start the DHW pump, turn off the boiler pump (if running), and modulate to bring the outlet temperature to the DHW boiler set point. The maximum firing rate may be limited in this mode if desired.

In Zone Mode it is assumed that the indirect DHW tank is piped as a zone on the primary loop. When a DHW demand begins, the control will turn on the DHW pump output, and raise the system temperature set point to the DHW boiler set point (if higher). The boiler pump will be turned on. The system pump may be forced on, forced off, or not changed, depending on the System Pump Mode selected (reference the Outdoor Knight Service Manual for details). In this mode, any low temperature zones (such as radiant heating) may need additional controls to limit the water temperature sent to those zones.

### Set DHW boiler target temperature

When in the DHW Mode, the control will modulate to maintain the boiler outlet temperature or system supply temperature to a set point. This set point is set at the factory to 180°F. If a different set point is desired, the appropriate parameter in the control must be changed. See the Outdoor Knight Boiler Service Manual for a detailed explanation of this procedure.

### Set maximum DHW fan speed

If the rated input of the indirect tank is less than the maximum output of the boiler, change the maximum DHW fan speed setting to limit the boiler output accordingly, see the Outdoor Knight Boiler Service Manual for a detailed explanation of this procedure.

### Set clock

#### NOTICE

Please note that the brackets ([ ]) denote screen status.

The SMART SYSTEM control has a built-in clock that it uses for its night setback feature and for logging events. This clock must be set when the boiler is installed, and anytime the boiler has been powered off for more than 4 hours. Use the following procedure to set the clock:

1. Press and hold the LEFT SELECT [MENU] key for at least 5 seconds.
2. The display changes to read [PASSWORD], with four (4) zeros below it.
3. Press the RIGHT SELECT [SAVE] key.
4. The display will then show a menu with the time and date and temperature unit.
5. Press the NAVIGATION dial twice.
6. Turn the NAVIGATION dial to adjust the hours. Press the NAVIGATION dial.
7. Turn the NAVIGATION dial to adjust the minutes. Press the NAVIGATION dial.

8. Turn the NAVIGATION dial to adjust the month. Press the NAVIGATION dial.
9. Turn the NAVIGATION dial to adjust the date. Press the NAVIGATION dial.
10. Turn the NAVIGATION dial to adjust the year. Press the RIGHT SELECT [SAVE] key.
11. Press the RIGHT SELECT [HOME] key.

#### NOTICE

The internal clock does not adjust for Daylight Savings Time and therefore, will require a manual adjustment.

The clock is automatically updated whenever a PC is connected and the Win Pro-Installer program is started.

### Configuration of the cascade

#### NOTICE

Please note that the brackets ([ ]) denote screen status.

When installed in a Cascade system, the individual controls must be programmed for cascade operation. This is accomplished by accessing the control parameters.

Press the [MENU] key for at least five (5) seconds. Input the Installer code as described in the Outdoor Knight Boiler Service Manual. Once the control parameters have been accessed, use the NAVIGATION dial to select the Control Mode parameters. Press the NAVIGATION dial to access these parameters.

Rotate the NAVIGATION dial to select the parameter "Cascade Address". Press the NAVIGATION dial to access this parameter. Each appliance in the Cascade system must be programmed with its own address. The boiler designated as the Leader will have an address of 0. The remaining boilers in the Cascade will be Members and have addresses from 1 - 7. Rotate the NAVIGATION dial to select the appropriate address. Press the RIGHT SELECT [SAVE] key.

Press the RIGHT SELECT [HOME] key to upload the address into the control. Repeat this procedure for all boilers in the Cascade, designating the Leader control and the Member controls.

# 8 Operating information

## General

### How the boiler operates

The outdoor boiler uses an advanced stainless steel heat exchanger and electronic control module that allows fully condensing operation. The blower pulls in air and pushes flue products out of the boiler through the heat exchanger and flue piping. The control module regulates blower speed to control the boiler firing rate. The gas valve senses the amount of air flowing into the boiler and allows only the right amount of gas to flow.

### How the control module operates

The SMART SYSTEM control module receives inputs from boiler sensors and external devices. The control module activates and controls the blower and gas valve to regulate heat input and switches the boiler, Domestic Hot Water (DHW), and system pumps on and off as needed. The user programs the module to meet system needs by adjusting control parameters. These parameters set operating temperatures and boiler operating modes. Boiler operation can be based on boiler outlet water temperature, boiler inlet water temperature, system temperature, a 0-10V signal or ModBus, depending on the parameter settings.

### Control inputs and outputs

#### Room thermostat

There are three (3) heat/loop demand connections available on this control. These inputs tell the boiler to provide water for space heating. Each demand connection has its own set point and outdoor air reset curve. When multiple demands have a call for heat the control will give priority to the demand with the highest set point.

*Example:* Assume that both heat/loop demand 1 and heat/loop demand 2 have a call for heat. Demand 1 has a set point of 110°F. Demand 2 has a set point of 140°F. The boiler will regulate the system temperature to 140°F until Demand 2 has been satisfied. Once Demand 2 has been satisfied the boiler will provide 110°F water to the system.

#### CAUTION

When multiple temperature loops are used, mixing valves are required for the protection of any low temperature loops.

#### SMART SYSTEM Multi-temp loop control

The outdoor boiler is capable of producing up to three (3) set point temperatures to meet different space heating demands. This device controls the temperatures of up to three (3) separate loops, based on the settings for the three (3) heat/loop demands (reference Lochinvar kit RLY30086).

#### 0 - 10V input (set point or power)

The outdoor boiler can be controlled by a Building Management System (BMS) provided that either an external energy management system is installed that reduces the boiler water temperature as the heating load decreases, the boiler is not used for any space heating, or the boiler is part of a modular or multiple boiler system having a total input of 300,000 Btu/hr or greater.

The control can be configured by the installer to use a 0 - 10 Vdc signal to either control set point or firing rate.

The outdoor boiler can also be programmed to accept a call for heat from a 0 - 10V signal, reference the Outdoor Knight Boiler Service Manual for a detailed explanation of this procedure.

#### DHW priority

The SMART SYSTEM control allows the connection of a DHW thermostat or tank sensor to the low voltage connection board. When a tank sensor is connected, the DHW thermostat input is ignored. When a boiler is programmed for DHW Normal Mode, the maximum firing rate can be limited to match the input rating of the indirect tank coil.

#### DHW / space heating (SH) cycling

If a DHW call for heat is received while a space heating call is in progress, and the DHW is in Normal Mode, the control will start the DHW pump and shut the boiler pump off. The system pump will remain on. For stand-alone boilers, if the space heating call is still active while the DHW call is in operation, the control will wait for 30 minutes (time adjustable by installer) then it will switch back to the space heating demand. There is a timer to switch from space heating to DHW and a timer to switch from DHW to space heating. The control will switch back and forth until one of the heat demands end.

#### Programmable controlling sensor

The control module is programmed to use the outlet sensor as the control sensor by default. If a system supply sensor is connected, the control automatically uses it as the control sensor. For stand-alone boilers, the control sensor can be changed by the installer to the inlet sensor. If the inlet sensor is chosen as the controlling sensor, it is recommended that the system supply sensor be installed in the system supply in order to provide the best control of the inlet temperature.

#### Anti-cycling

After the burner turns off, the control will delay the next burner cycle for a set time period (time is adjustable by the installer). The time delay will be bypassed if the inlet water temperature drops too far during the delay.

#### Boiler and system pump control

The boiler pump will run whenever the burner is firing, unless the DHW is programmed for Normal Mode and the boiler is heating the DHW tank. The boiler pump will run during Freeze Protection Mode as well. It will continue to run for a short time after the burner turns off or the Freeze Protection Mode ends.

The system pump will run whenever there is a space heating call for heat, or the boiler goes into Freeze Protection Mode. It may be programmed to run during a DHW call for heat when the DHW is programmed for Zone Mode. It will continue to run for a short time after the end of the heat demand or the Freeze Protection Mode. The system pump can be programmed to run continuously if desired, except during outdoor shutdown and/or a DHW call for heat.

## 8 Operating information

### Temperature control

#### Modulation

The outdoor boiler is capable of modulating its firing rate from a minimum of 20% to a maximum of 100%. The firing rate is dictated by the call for heat (i.e., space heating or domestic hot water), the heating load, ramp delay (if enabled), and various other temperature limitations.

#### Ramp delay

For systems with lower flow, the SMART SYSTEM can limit the firing rate (when enabled) when a space heating call for heat starts, or when switching from a DHW call for heat to a space heating call for heat. There are six (6) limits that can be programmed, as well as six (6) time intervals corresponding to each limit. The sixth limit will also limit the firing rate for the rest of the call for heat.

#### Gradient limiting

If during operation of the boiler the outlet water temperature is rising too quickly, the control will reduce the firing rate to its lowest setting.

#### Outdoor air reset

With the outdoor air sensor connected, the control module will calculate the set points of the three (3) space heating demands based on the programmed reset curves. The installer can change the slope of the reset curves by several adjustable parameters. The user can limit the maximum set point for the system using the space heating set points.

#### Boost function

If outdoor air reset is active, and any space heating demand has been active continuously for a set period of time (time adjustable by installer) and there has been no DHW demands, the control will increase the set point of that demand by a fixed number of degrees (adjustable by installer). This process will continue until the space heating demand ends, the set point reaches the programmed set point or a maximum of 20 increases has occurred. Once the system heat demand is satisfied, the set point will revert to the value determined by the reset curve.

#### Night setback

The controller may be programmed to reduce the space heating and DHW set points during certain times each week. Seven different start and stop times may be programmed for the space heating setback and seven start and stop times for the DHW setback. Any night setback event scheduled within the next seven (7) days can be temporarily bypassed if desired.

#### Flame current support

To prevent nuisance shutdowns when the boiler is firing at minimum rates, the control will increase the firing rate when the flame signal drops too low.

### Protection features

#### Outlet temperature, flue temperature, and temperature rise limiting

The outlet temperature is monitored by the boiler outlet temperature sensor. When the outlet temperature exceeds 185°F, the unit will reduce the fan speed. If the outlet water temperature exceeds 195°F the control will shut the unit down until it cools off.

The control module monitors the flue temperature by a sensor located in the flue exhaust. If the flue temperature exceeds 215°F the control will reduce the maximum fan speed. If the flue temperature exceeds 240°F the control will shut the unit down. The unit will restart automatically once the flue temperature drops 25°F and the minimum off time has expired.

The control monitors the temperature difference between the inlet and the outlet sensor. If this difference exceeds 55°F the control will reduce the maximum fan speed. If the temperature difference exceeds 60°F the control will shut the unit down. The unit will restart automatically once the temperature difference has dropped below 55°F and the minimum off time has expired.

#### Freeze protection

DO NOT install the boiler where it is likely to freeze.

The following integral feature of the SMART SYSTEM control module provides some protection for the boiler only -- not for the system.

- The SMART SYSTEM control module provides freeze-up protection as follows when the boiler water temperature drops below 45°F:
- Below 45°F, the boiler and system pumps operate constantly.
- Below 37°F, the boiler turns on.
- Boiler and pumps turn off if boiler water temperature rises above 45°F.
- Lower temperatures may be programmed for systems with anti-freeze solutions.

#### NOTICE

When system return temperatures are maintained below the dew point, condensation will form on the inside of the boiler jacket causing some internal sheet metal components to rust.

#### CAUTION

This feature of the SMART SYSTEM control module does not eliminate the possibility of freezing. The installation must still use recognized design, installation and maintenance practice to prevent freeze potential for the boiler and system.



## 8 Operating information *(continued)*

### Monitor external limits

Connections are provided on the connection board for external limits such as a flow switch, low water cutoff and gas pressure switches. The SMART SYSTEM will shut off the burner and inhibit relighting whenever any of these external limits open.

### Run-time and alarm outputs

The boiler provides dry contacts for indicating when the boiler is running, and when it is unable to operate.

### Run-time and cycle counting

The control uses two timers to monitor the total hours of burner operation. One timer monitors the time the boiler is firing in the Space Heating Mode. The other timer monitors the time the boiler is firing in the DHW Mode.

The control uses two (2) ignition counters to monitor the amount of boiler cycles. The first counter counts all ignitions of the control. The second counter counts only ignition attempts that have failed.

### Service reminder

The control can be programmed for service reminder notification. This notification will become active when either a set time frame has expired, or a set amount of running hours or cycles has expired (all adjustable by the installer). The display will show a Maintenance Required screen. The installer's name and phone number can be programmed into the control. This information will appear on the Maintenance Required screen. The service reminder notification can be reset or disabled by the installer.

The time dependent feature has been disabled by the manufacturer. To enable this feature change the parameter to the desired time interval, reference the Outdoor Knight Service Manual for details regarding parameters.

### Error logging

The control will hold in memory the last 10 lockouts as well as the last 10 blockings. The date and time of the occurrence will be recorded as well. Only the 10 most current occurrences of each will be held in memory.

### Boiler temperature regulation

#### Operating temperature (target)

The SMART SYSTEM control module senses water temperature and regulates boiler firing and firing rate to achieve a target temperature. The target temperature can be set between 32°F and 190°F.

- Target temperature is calculated as described in the “Outdoor Reset Operation” section, when the outdoor sensor is connected.
- If the outdoor sensor is not connected, the target temperature is fixed at SH (1 - 3) set points. An outdoor sensor fault will remain on the display screen until the outdoor sensor is reconnected.

#### High limit operations

The outdoor boiler is equipped with adjustable automatic reset and manual reset high limits. The automatic reset high limit has a maximum set point of 200°F and the manual reset high limit has a maximum set point of 210°F.

When the outlet temperature exceeds 200°F, the automatic high limit action occurs. The boiler shuts down until the outlet water temperature cools below 190°F, and a 60 second timer has expired. If the outlet temperature continues to increase, the manual reset high limit action will occur at 210°F.

### High limit test procedure

#### NOTICE

Please note that the brackets ([]) denote screen status.

1. Turn ON the main power to the boiler by placing the ON/OFF switch in the ON position.
2. From the Status Screen, press the NAVIGATION dial to access the Set Points Screen.
3. Press the LEFT SELECT (LIMITS) key.
4. Select the manual reset high limit (MRHL) by rotating the NAVIGATION dial counterclockwise, then press the NAVIGATION dial.
5. Decrease the set point of the MRHL to below the current outlet temperature (or to its minimum setting, whichever is higher) by turning the NAVIGATION dial counterclockwise.
6. Press the RIGHT SELECT [SAVE] key.
7. Press the RIGHT SELECT [HOME] key. The new parameter will upload to the control.
8. If the current outlet temperature is above the new MRHL set point, the MRHL will function causing boiler lockout. If this occurs, skip to Step 11.
9. If the current outlet temperature is below the new MRHL set point, locate the pinhole (SERVICE button) below the RESET button on the display board. Insert a thin probe (such as a paper clip) into the hole and press the button continuously for five (5) seconds to place the boiler into Service Mode. In Service Mode, the boiler will fire at ignition speed and will then modulate up to full fire.
10. Once the outlet temperature rises up to the MRHL set point, the MRHL will function, causing the boiler to shut down and lock out.
11. Repeat Steps 2, 3 and 4.
12. Set the MRHL to the appropriate set point by turning the NAVIGATION dial clockwise.
13. Repeat Steps 6 and 7.
14. Press the RESET button to clear the lockout.
15. If needed, press the RIGHT SELECT [STOP] key to exit Service Mode.

### Low water cutoff protection

1. The SMART SYSTEM control module uses temperature sensing of both supply and return areas of the heat exchanger. If the flow rate is too low or the outlet temperature too high, the control module modulates and shuts the boiler down. This ensures boiler shutdown in the event of low water or low flow conditions.
2. Some codes and jurisdiction may accept these integral features of the control in lieu of requiring an additional limit control or low water cutoff. Consult local jurisdiction to determine. A low water cutoff is available from the factory (WTR30024).

## 8 Operating information

### Outdoor reset operation

#### Target temperature with outdoor reset

This feature improves the system's efficiency by decreasing set point as the outdoor temperature warms up. Energy Efficiency Standards require the use of a control that automatically adjusts set point in relation to heat demand. In the absence of an external energy management system, this feature **MUST BE** used.

See the Outdoor Knight Boiler Service Manual to change the settings.

#### Reset curve

The reset curve looks at outdoor air temperature and adjusts the set point in relation to heat demand.

### Cascade

When multiple boilers are installed, they can be wired together in a cascade sequence. A maximum of eight boilers can be controlled from a single control. In this application one boiler would be designated as the Leader control and all others would be designated as Member controls. The Leader control can be programmed to use Lead/Lag or Efficiency Optimization control methods.

Once the Leader boiler receives a call for heat from a room thermostat, BMS, or ModBus, the control will determine what the set point will be. If outdoor air reset is desired, connect the outdoor air sensor to the terminals on the Low Voltage Connection Board on the Leader boiler. The set point will be calculated based on the programmed reset curve parameters. See the Outdoor Knight Boiler Service Manual to program the reset curve. If outdoor air reset is not desired, do not connect the outdoor air sensor. A fixed temperature set point can be programmed into the control. See page 37 of this manual to program the set point.

If the water temperature at the system supply sensor is less than the set point + the turn-off offset - the off-on differential, then the control will initiate a call for heat on the Cascade (see the Outdoor Knight Boiler Service Manual for an explanation of the offset and differential). The Leader will energize the lead boiler on the Cascade. For a new startup this will be the Leader boiler.

### Sequence of the cascade

To equalize the run time of all boilers on the Cascade, the firing sequence will automatically be changed at set intervals.

During the first 24 hours of operation, the sequence will change every hour. After that, the sequence will change every 24 hours. The switching on/off sequence will be as follows:

TIME	SWITCHING ON SEQUENCE
Start	L-M1-M2-M3-M4-M5-M6-M7
1 hour	M1-M2-M3-M4-M5-M6-M7-L
2 hours	M2-M3-M4-M5-M6-M7-L-M1

If a boiler locks out or is used to heat an indirect DHW tank, it will automatically be given the lowest priority for the rest of that 24 hour period.

### DHW, Night Setback, and Ramp Delay operation with cascade

For Normal Mode DHW operation any boiler(s) in the Cascade can be selected to provide heat for a DHW call. Select a boiler to be designated as the DHW boiler. Connect the DHW thermostat or sensor to the terminals on the Low Voltage Connection Board marked for the corresponding device. When the boiler receives a DHW call, the Leader control will take that boiler out of the Cascade sequence. If another boiler is available, the Leader will start it up to take its place.

The DHW boiler will adjust its set point to the programmed DHW boiler set point and will adjust its firing rate to maintain this. Once the DHW call has been satisfied, the Leader control will place that boiler back into the Cascade sequence.

Switching of the boiler between DHW operation and SH operation when there is a call for both does not occur in Cascade Mode.

When DHW is programmed for Zone Mode, connect the DHW thermostat or tank sensor to the Leader boiler. When a DHW call is received, the Leader will modulate the entire Cascade to bring the system supply temperature up to the DHW boiler set point.

Night Setback operation of the boilers within the Cascade is available. Programming of the Night Setback will be done through the Leader boiler. Refer to the Outdoor Knight Boiler Service Manual for information regarding Night Setback.

Ramp Delay operation of the boilers as described in the Outdoor Knight Boiler Service Manual is available when the boilers are part of a Cascade system.

## 8 Operating information *(continued)*

### Sequence of operation

OPERATION	DISPLAY
1. Upon a call for heat, the gas pressure switch(es) must be closed.	<p style="text-align: center;"><b>START</b> </p> <p>SYSTEM: 116°F                      TANK: 128°F(125)                      OUTDOOR: 56°F</p> <hr/> <p>MENU   SCREEN SHDN</p>
2. Once the gas pressure switch(es) are closed, the control turns on the appropriate pumps (system and boiler pumps for space heating, DHW pump for DHW). The flow switch and/or LWCO must close.	<p style="text-align: center;"><b>START</b> </p> <p>SYSTEM: 116°F                      TANK: 128°F(125)                      OUTDOOR: 56°F</p> <hr/> <p>MENU   SCREEN SHDN</p>
3. The air pressure switch and blocked drain switch must close.	<p style="text-align: center;"><b>START</b> </p> <p>SYSTEM: 116°F                      TANK: 128°F(125)                      OUTDOOR: 56°F</p> <hr/> <p>MENU   SCREEN SHDN</p>
4. The control starts the prepurge cycle by initiating the blower.	<p style="text-align: center;"><b>PRE-PURGE</b> </p> <p>SYSTEM: 117°F (118)                      TANK: 128°F (130)                      OUTDOOR: 56°F</p> <hr/> <p>MENU   SCREEN SHDN</p>
5. The control starts the trial for ignition by firing the spark electrode and opening the gas valve.	<p style="text-align: center;"><b>IGNITION</b> </p> <p>SYSTEM: 117°F (118)                      DHW TANK: 128°F (130)                      OUTDOOR: 56°F</p> <hr/> <p>MENU   SCREEN SHDN</p>
6. If flame is not detected after the sparking ends, the control will perform a post-purge, then start another prepurge cycle and try to light the burner again. The control will perform a total of 4 attempts before locking out.	<p style="text-align: center;"><b>POST-PURGE</b> </p> <p>SYSTEM: 117°F (118)                      TANK: 128°F (130)                      OUTDOOR: 56°F</p> <hr/> <p>MENU   SCREEN SHDN</p>
7. If flame is detected, it holds the firing rate steady for a few seconds to let the flame stabilize, then it begins to modulate the firing rate based on a set point or some other command (such as a 0-10V BMS signal).	<p style="text-align: center;"><b>42%</b> </p> <p>SYSTEM: 117°F (118)                      TANK: 128°F (130)                      OUTDOOR: 56°F</p> <hr/> <p>MENU   SCREEN SHDN</p>

# 8 Operating information

## Sequence of operation *(continued)*

OPERATION	DISPLAY
8. If the space heating call for heat is active, and the tank thermostat or sensor starts a DHW call for heat, the boiler will switch to the DHW mode. If programmed for normal DHW operation (not as a zone), the DHW pump will turn on first, then the boiler pump will turn off 2 seconds later. This will divert the boiler's outlet water from the heating system and send it to the tank coil instead. The control will then modulate to maintain the outlet temperature to the DHW boiler set point.	<pre>                     42% 🔥 1 🏠                     SYSTEM: 117°F(118)                     TANK: 124°F(130)                     OUTDOOR: 56°F                     -----                     MENU ⏪SCREEN SHDN                     </pre>
9. If the boiler is not part of a Cascade, and both the space heating and DHW calls for heat remain active long enough, the boiler will switch back and forth between the two heating modes until one of them is satisfied.	<pre>                     42% 🔥 🏠 🏠                     SYSTEM: 117°F(118)                     TANK: 124°F(130)                     OUTDOOR: 56°F                     -----                     MENU ⏪SCREEN SHDN                     </pre>
10. Once both calls for heat are satisfied, the control will turn off the burner. The blower will continue to run during the postpurge period.	<pre>                     POST-PURGE                     SYSTEM: 117°F(118)                     TANK: 128°F(130)                     OUTDOOR: 56°F                     -----                     MENU ⏪SCREEN SHDN                     </pre>
11. Any pumps that are running will continue to run for their respective pump delay times before turning off, unless programmed to remain on continuously. A 60 second anti-cycle period will start, which will delay any new call for heat until it times out.	<pre>                     BLOCKED                     SYSTEM: 117°F(118)                     TANK: 124°F(130)                     OUTDOOR: 56°F                     -----                     MENU ⏪SCREEN SHDN                     </pre>
12. In Standby, ready to start a new cycle.	<pre>                     STANDBY                     SYSTEM: 117°F                     DHW TANK: 128°F(130)                     OUTDOOR: 56°F                     -----                     MENU ↓SETPOINTS SHDN                     </pre>

## 8 Operating information *(continued)*

### Outdoor Knight boiler control module

Use the control panel (FIG. 8-1) to set temperatures, operating conditions, and monitor boiler operation.

**Figure 8-1** Control Panel

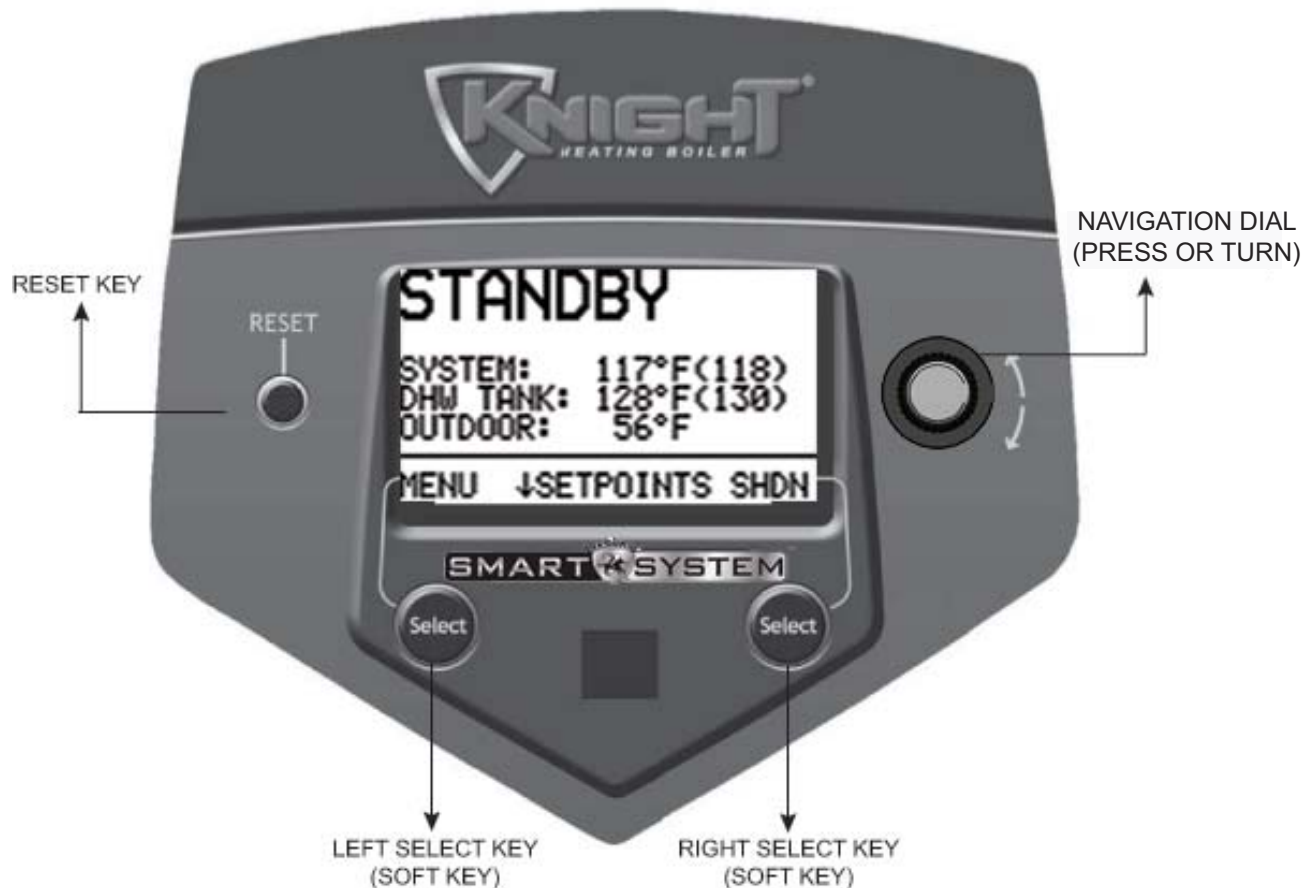

The information on the bottom of the display shows the functions of the two SELECT keys (on either corner), and the NAVIGATION dial (in the center):

MENU = Left SELECT Key  
 SETPOINTS = NAVIGATION Dial - Pressing Down  
 SHDN = Right SELECT Key

#### Access modes

##### User

The user can adjust space heating and tank target temperatures by pressing the NAVIGATION dial when “↓SETPOINTS” is flashing at the bottom of the display. The date and time, and the temperature units can also be changed (see page 38).

##### Installer

Most parameters are available only to the installer, accessible by entering the installer password, see the Outdoor Knight Boiler Service Manual.

Saving parameters *(reference the Parameter Table in the Outdoor Knight Boiler Service Manual)*

#### NOTICE

Please note that the brackets ([]) denote screen status.

##### To save parameters and exit programming:

Press the RIGHT SELECT [SAVE] key and then press the RIGHT SELECT [HOME] key.

##### To enter a parameter and continue programming:

Press the RIGHT SELECT [SAVE] key 1 time to return to the parameter listings; press again to return to the menu listings. Remember to press the RIGHT SELECT [HOME] key when finished programming in order to save the changes made.

See the Outdoor Knight Boiler Service Manual for a detailed description of parameters and access modes.

## 8 Operating information

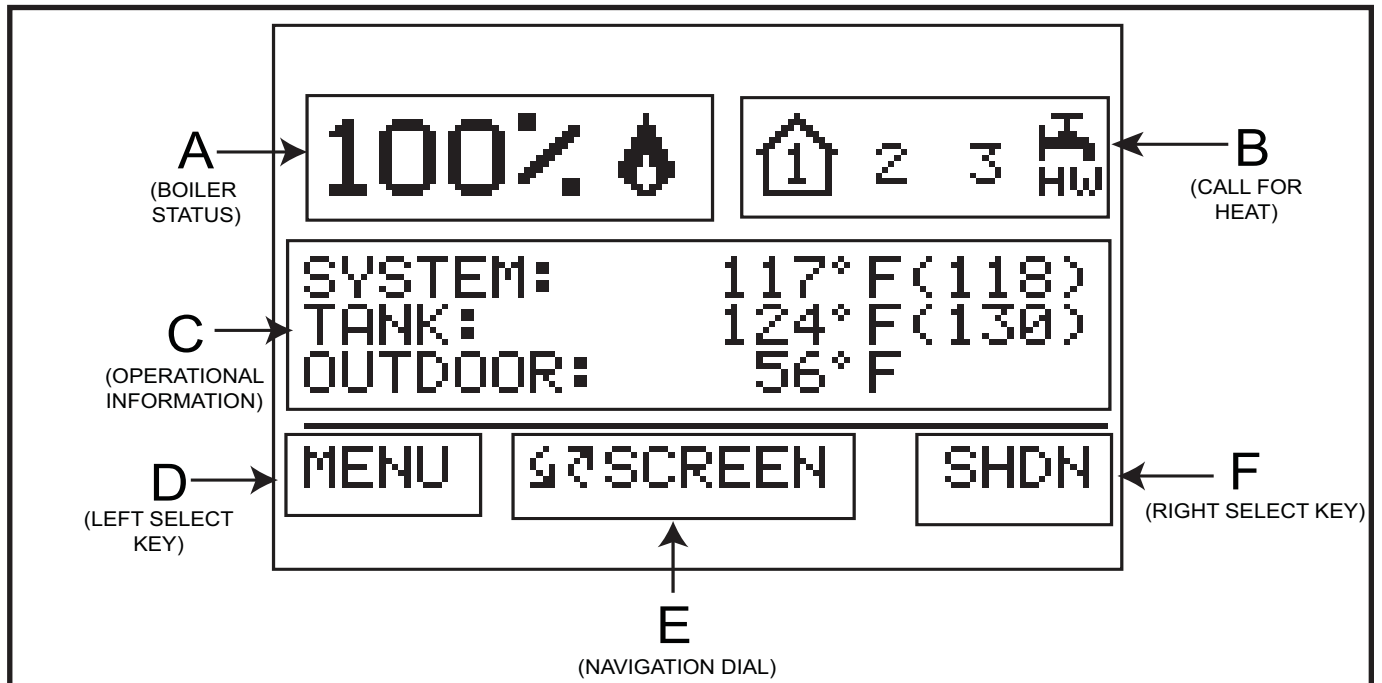
**Figure 8-2** Status Display Screen

Status Display Screens		
Section	Display	Description
A (Boiler Status Bar)	STANDBY	The unit has not received a call for heat from a remote thermostat nor has it received a call for heat from a DHW thermostat.
	START	The unit has begun a burn cycle and is checking all safety circuits.
	PREPURGE	The unit has initiated a prepurge period on a call for heat.
	IGNITION	The unit has begun a spark period to ignite the main burner.
	% 🔥	The unit has fired and is running at the displayed percentage.
	POSTPURGE	The call for heat has been satisfied and the unit runs the fan for an additional postpurge period to clear the combustion chamber and vent system of residual flue products.
	SHUTDOWN	The unit has been placed in the OFF position.
	SETPOINT MET	The controlled temperature has exceeded its set point and its offset.
	BLOCKED	The unit has detected a condition that has temporarily interrupted the current call for heat.
B (Call for Heat Indicators)	1	Heat/Loop Demand 1 has a call for heat.
	2	Heat/Loop Demand 2 has a call for heat.
	3	Heat/Loop Demand 3 has a call for heat.
	🔥 HW	The tank thermostat or sensor has a call for heat.
	① ② ③	Indicates which Heat/Loop Demand has priority.
	🏠	The unit is being controlled by a 0 - 10V BMS signal.
	🏠	The unit is supplying heat while in Cascade Mode.

## 8 Operating information *(continued)*

Status Display Screens <i>(cont'd)</i>		
Section	Display	Description
<b>C</b> <b>(Operational Information)</b>	SYSTEM:	The temperature read by the system supply sensor (if connected).
	TANK:	The temperature read by the tank sensor (if connected).
	OUTDOOR:	The temperature read by the outdoor sensor.
	INLET TEMP:	The temperature read at the inlet to the heat exchanger.
	OUTLET TEMP:	The temperature read at the outlet of the heat exchanger.
	DELTA T:	The temperature difference between the inlet and the outlet of the heat exchanger.
	FLUE TEMP:	The temperature read by the flue sensor.
	FLAME CURRENT:	The current measured by the flame sense circuit.
	FAN SPEED:	The speed of the combustion blower.
	BOILER PUMP:	The status of the boiler pump output.
	SYSTEM PUMP:	The status of the system pump output.
	DHW PUMP:	The status of the DHW pump output.
	BMS VOLTAGE:	The voltage received from a BMS system.
	BLR PUMP OUTPUT:	The speed signal sent to a variable speed boiler pump in percent.
	SYS PUMP INPUT:	The speed signal received from a variable speed system pump control.
	RATE OUTPUT:	A 0 - 10V signal indicating the firing rate of the boiler.
	SH RUN HOURS:	The total hours of operation in the Space Heating Mode.
	SH CYCLES:	The total burner cycles in the Space Heating Mode.
	DHW RUN HOURS:	The total hours of operation in the DHW Mode.
	DHW CYCLES:	The total burner cycles in the DHW Mode.
LAST 10 FAULTS NO:	The last 10 lockouts.	
NIGHT SETBACK	Shows the next Night Setback trigger (if active).	

## 8 Operating information

Status Display Screens (cont'd)		
Section	Display	Description
<b>D</b> <b>(LEFT SELECT key function)</b>	MENU	Press and hold the LEFT SELECT key for 5 seconds to enter the Menu Screen.
	EXIT	Press the LEFT SELECT key to exit the current screen or setting.
	YES	Press the LEFT SELECT key to confirm that the boiler needs to shutdown.
	LIMITS	Press the LEFT SELECT key to enter the screen that allows you to adjust the limit settings.
	HOME	Press the LEFT SELECT key to return to the Status Screen and upload parameter changes.
	SKIP	Press the LEFT SELECT key when in the Night Setback Screen to access the Night Setback Skip Screen.
<b>E</b> <b>(NAVIGATION Dial Function)</b>	↻ SCREEN	Turning the NAVIGATION dial will select the next or previous Status Screen.
	↓NEXT	Pressing the NAVIGATION dial will show the next fault, NSB (Night Setback) trigger, or ramp delay setting.
	↓ SELECT	Pressing the NAVIGATION dial will select the setting indicated by the cursor.
	↓SETPOINTS	Pressing the NAVIGATION dial will display the Set Points Screen.
	↻ SCROLL	Turning the NAVIGATION dial will move the cursor up or down.
	↻ ADJUST	Turning the NAVIGATION dial will increase or decrease the current setting.
<b>F</b> <b>(RIGHT SELECT key function)</b>	SHDN	Press the RIGHT SELECT key to turn the boiler OFF.
	ON	Press the RIGHT SELECT key to turn the boiler ON.
	NO	Press the RIGHT SELECT key to cancel the shutdown operation.
	SAVE	Press the RIGHT SELECT key to save the current change.
	HOME	Press the RIGHT SELECT key to return to the Status Screen and upload parameter changes.



# 9 Maintenance

## Maintenance and annual startup

**Table 9A** Service and Maintenance Schedules

Service technician (see the following pages for instructions)		Owner maintenance (see the Outdoor Knight User's Information Manual for instructions)	
<b>ANNUAL START-UP</b>	<b>General:</b>	<b>Daily</b>	<ul style="list-style-type: none"> <li>• Check boiler area</li> <li>• Check pressure / temperature gauge</li> </ul>
	<ul style="list-style-type: none"> <li>• Address reported problems</li> <li>• Inspect interior; clean and vacuum if necessary;</li> <li>• Clean condensate trap and fill with fresh water</li> <li>• Check for leaks (water, gas, flue, condensate)</li> <li>• Verify flue and air openings in good condition and free of obstruction</li> <li>• Check system water pressure/system piping/expansion tank</li> <li>• Check control settings</li> <li>• Check ignition and flame sense electrodes (sand off any deposits; clean and reposition)</li> <li>• Check wiring and connections</li> <li>• Perform start-up checkout and performance verification per Section 7 of this manual.</li> <li>• Flame inspection (stable, uniform)</li> <li>• Flame signal (at least 10 microamps at high fire)</li> <li>• Clean the heat exchanger if flue temperature is more than 54°F above return water temperature.</li> </ul>	<b>Monthly</b>	<ul style="list-style-type: none"> <li>• Check air and vent termination screens</li> <li>• Check relief valve</li> <li>• Check condensate drain system</li> </ul>
	<p><b>If combustion or performance indicate need:</b></p> <ul style="list-style-type: none"> <li>• Clean heat exchanger</li> <li>• Remove and clean burner using compressed air only</li> <li>• Clean the blower wheel</li> </ul>	<b>Periodically</b>	<ul style="list-style-type: none"> <li>• Test low water cutoff (if used)</li> <li>• Reset button (low water cutoff)</li> </ul>
		<b>Every 6 months</b>	<ul style="list-style-type: none"> <li>• Check boiler piping (gas and water) for leaks</li> <li>• Operate relief valve</li> </ul>
		<b>End of season months</b>	<ul style="list-style-type: none"> <li>• Shut boiler down (unless boiler used for domestic hot water)</li> </ul>

## 9 Maintenance

**⚠ WARNING** Follow the service and maintenance procedures given throughout this manual and in component literature shipped with the boiler. Failure to perform the service and maintenance could result in damage to the boiler or system. Failure to follow the directions in this manual and component literature could result in severe personal injury, death, or substantial property damage.

**⚠ WARNING** The boiler should be inspected annually only by a qualified service technician. In addition, the maintenance and care of the boiler designated in Table 9A and explained on the following pages must be performed to assure maximum boiler efficiency and reliability. Failure to service and maintain the boiler and system could result in equipment failure.

**⚠ WARNING** Electrical shock hazard – Turn off power to the boiler before any service operation on the boiler except as noted otherwise in this instruction manual. Failure to turn off electrical power could result in electrical shock, causing severe personal injury or death.

### Address reported problems

1. Inspect any problems reported by the owner and correct before proceeding.

### Inspect boiler area

1. Verify that boiler area is free of any combustible materials, gasoline and other flammable vapors and liquids.
2. Verify that air intake area is free of any of the contaminants listed in Section 1 of this manual. If any of these are present in the boiler intake air vicinity, they must be removed.

### Inspect boiler interior

1. Remove the front access cover and inspect the interior of the boiler.
2. Vacuum any sediment from inside the boiler and components. Remove any obstructions.

### Clean condensate trap

1. Inspect the condensate drain line, condensate PVC fittings, and condensate trap.
2. Remove the PVC cap retaining screw from the PVC cap (FIG. 9-1).
3. Remove the 2 inch PVC cap with the switch located at the top of the trap (FIG. 9-1).
4. Remove any sediment in the trap.
5. Fill with fresh water until the water begins to pour out of the drain.
6. Replace the cap. Press the cap onto the trap until the cap makes contact with the drain.
7. Replace the retaining screw.

**Figure 9-1** Condensate Trap

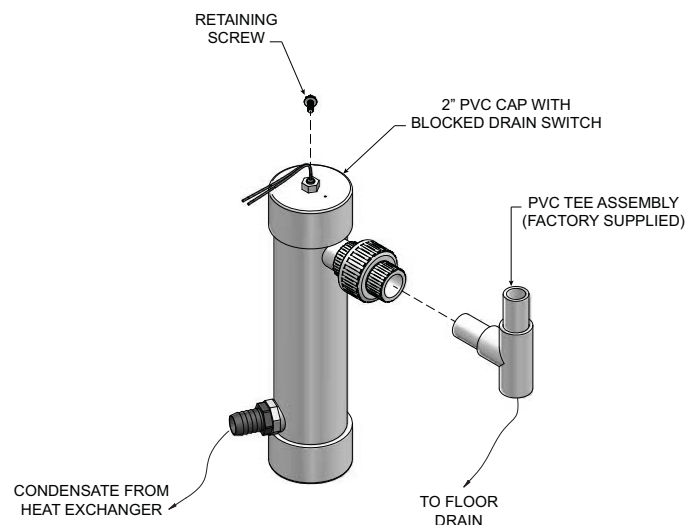

**⚠ WARNING** The condensate trap must be filled with water during all times of boiler operation to avoid flue gas emission from the condensate drain line. Failure to fill the trap could result in severe personal injury or death.

### Check all piping for leaks

**⚠ WARNING** Eliminate all system or boiler leaks. Continual fresh makeup water will reduce boiler life. Minerals can build up in sections, reducing heat transfer, overheating heat exchanger, and causing heat exchanger failure. Leaking water may also cause severe property damage.

1. Inspect all water and gas piping and verify to be leak free.
2. Look for signs of leaking lines and correct any problems found.
3. Check gas line using the procedure found in Section 4 - Gas Connections.

## 9 Maintenance *(continued)*

### Flue vent system and air piping

1. Visually inspect the entire flue gas venting system and air piping for blockage, deterioration or leakage. Repair any joints that show signs of leakage.
2. Verify that boiler vent discharge and air intake are clean and free of obstructions.

**⚠ WARNING** Failure to inspect for the above conditions and have them repaired can result in severe personal injury or death.

### Check water system

1. Verify all system components are correctly installed and operational.
2. Check the cold fill pressure for the system. Verify it is correct (must be a minimum of 12 psi).
3. Watch the system pressure as the boiler heats up (during testing) to ensure pressure does not rise too high. Excessive pressure rise indicates expansion tank sizing or performance problem.
4. Inspect automatic air vents and air separators. Remove air vent caps and briefly press push valve to flush vent. Replace caps. Make sure vents do not leak. Replace any leaking vents.

### Check expansion tank

1. Expansion tanks provide space for water to move in and out as the heating system water expands due to temperature increase or contracts as the water cools. Tanks may be open, closed or diaphragm or bladder type. See Section 3 - Hydronic Piping for suggested best location of expansion tanks and air eliminators.

### Check boiler relief valve

1. Inspect the relief valve and lift the lever to verify flow. Before operating any relief valve, ensure that it is piped with its discharge in a safe area to avoid severe scald potential. Read Section 3 - Hydronic Piping before proceeding further.

**⚠ WARNING** Safety relief valves should be re-inspected AT LEAST ONCE EVERY THREE YEARS, by a licensed plumbing contractor or authorized inspection agency, to ensure that the product has not been affected by corrosive water conditions and to ensure that the valve and discharge line have not been altered or tampered with illegally. Certain naturally occurring conditions may corrode the valve or its components over time, rendering the valve inoperative. Such conditions are not detectable unless the valve and its components are physically removed and inspected. This inspection must only be conducted by a plumbing contractor or authorized inspection agency – not by the owner. Failure to re-inspect the boiler relief valve as directed could result in unsafe pressure buildup, which can result in severe personal injury, death, or substantial property damage.

**⚠ WARNING** Following installation, the valve lever must be operated AT LEAST ONCE A YEAR to ensure that waterways are clear. Certain naturally occurring mineral deposits may adhere to the valve, rendering it inoperative. When manually operating the lever, water will discharge and precautions must be taken to avoid contact with hot water and to avoid water damage. Before operating lever, check to see that a discharge line is connected to this valve directing the flow of hot water from the valve to a proper place of disposal. Otherwise severe personal injury may result. If no water flows, valve is inoperative. Shut down the boiler until a new relief valve has been installed.

2. After following the above warning directions, if the relief valve weeps or will not seat properly, replace the relief valve. Ensure that the reason for relief valve weeping is the valve and not over-pressurization of the system due to expansion tank waterlogging or undersizing.

## 9 Maintenance

### Inspect ignition and flame sense electrodes

1. Remove the ignition and flame sense electrodes from the boiler heat exchanger access cover.
2. Remove any deposits accumulated on the ignition/flame sense electrode using sandpaper. If the electrodes cannot be cleaned satisfactorily, replace with new ones.
3. Replace ignition/flame sense electrode, making sure gasket is in good condition and correctly positioned.

### Check ignition ground wiring

1. Inspect boiler ground wire from the heat exchanger access cover to ground terminal strip.
2. Verify all wiring is in good condition and securely attached.
3. Check ground continuity of wiring using continuity meter.
4. Replace ground wires if ground continuity is not satisfactory.

### Check all boiler wiring

1. Inspect all boiler wiring, making sure wires are in good condition and securely attached.

### Check control settings

1. Set the SMART SYSTEM control module display to Parameter Mode and check all settings. See Section 1 of Outdoor Knight Boiler Service Manual. Adjust settings if necessary. See Section 1 of the Outdoor Knight Boiler Service Manual for adjustment procedures.
2. Check settings of external limit controls (if any) and adjust if necessary.

### Perform start-up and checks

1. Start boiler and perform checks and tests specified in Section 7 - Start-up.
2. Verify cold fill pressure is correct and that operating pressure does not go too high.

### Check burner flame

1. Inspect flame through observation window.
2. If the flame is unsatisfactory at either high fire or low fire, turn off boiler and allow boiler to cool down. Remove the burner and clean it thoroughly using a vacuum cleaner or compressed air. Do not use compressed air to clean burner if performed inside a building.
3. Remove the burner, reference FIG. 9-2 below.
4. When replacing the burner, ensure gasket is in good condition and positioned correctly (FIG. 9-2).

**Figure 9-2** Burner Assembly

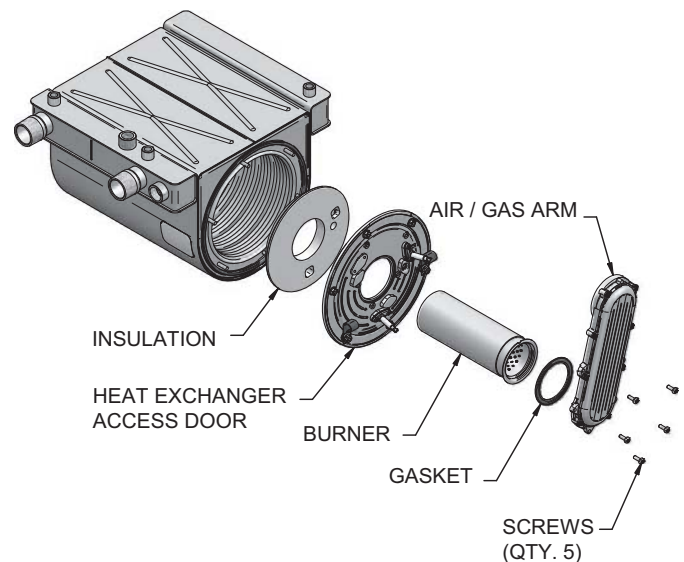

IMG00447

### Check flame signal

1. At high fire the flame signal shown on the display should be at least 10 microamps.
2. A lower flame signal may indicate a fouled or damaged flame sense electrode. If cleaning the flame sense electrode does not improve, ground wiring is in good condition, and ground continuity is satisfactory, replace the flame sense electrode.
3. See Section 3 - Troubleshooting of the Outdoor Knight Boiler Service Manual for other procedures to deal with low flame signal.

## 9 Maintenance *(continued)*

### Review with owner

1. Review the Outdoor Knight Boiler User's Information Manual with the owner.
2. Emphasize the need to perform the maintenance schedule specified in the Outdoor Knight Boiler User's Information Manual (and in this manual as well).
3. Remind the owner of the need to call a licensed contractor should the boiler or system exhibit any unusual behavior.
4. Remind the owner to follow the proper shutdown procedure and to schedule an annual start-up at the beginning of the next heating season.

### Cleaning boiler heat exchanger

For recommended materials; including brush, appropriate extension(s), refractory cover, and detailed instructions see Table 9B - Heat Exchanger Cleaning Kits.

1. Shut down boiler:
  - Follow the "To Turn Off Gas to Appliance" instructions for the boiler in Section 7 - Startup.
  - Do not drain the boiler unless it will be exposed to freezing temperatures. If using freeze prevention fluid in system, do not drain.
2. Allow time for the boiler to cool to ambient temperature if it has been firing.
3. Remove the nuts securing the heat exchanger access cover to the heat exchanger and set aside.
4. Remove the heat exchanger access cover, burner, and gas/air arm assembly.

#### **WARNING**

The boiler contains ceramic fiber materials. Use care when handling these materials per instructions in the Service Manual. Failure to comply could result in severe personal injury.

5. Remove the condensate hose from the heat exchanger end. Connect a field supplied 3/4" diameter hose to a drain pan. Using field supplied means, cover the refractory in the back of the combustion chamber of the heat exchanger.
6. Use a vacuum cleaner to remove any accumulation on the boiler heating surfaces. Do not use any solvent.
7. Brush the heat exchanger while dry using a nylon bristle brush. **Caution:** DO NOT use a metal brush. Re-vacuum the heat exchanger.
8. Finish cleaning using a clean cloth dampened with warm water. Rinse out debris with a low pressure water supply.
9. Allow the heat exchanger to thoroughly dry.
10. Remove the field supplied rear refractory cover from the back of the combustion chamber of the heat exchanger and reassemble.

11. Close isolation valves on piping to isolate boiler from system. Attach a hose to the boiler drain and flush boiler thoroughly with clean water by using purging valves to allow water to flow through the water make-up line to the boiler.
12. Perform start-up and check-out procedures in the Check Flame and Combustion - Section 7 - Startup on pages 35 and 37 of this manual.
13. Replace the access cover and restore boiler to operation.

**Table 9B** Heat Exchanger Cleaning Kits

Model	Kit Number	Part Number	Component Description
151 - 286	KIT30063	CTN20005	Rear Refractory Cover
		MSC20083*	Nylon 4" Wheel Brush*
		MSC20084	3mm Allen Wrench
		MSC20086	1/4" x 24" Drill Extension

#### **CAUTION**

\* Do NOT use a metal brush. Only use the kit provided brush or an equivalent replacement nylon brush.

**Figure 9-3** Rope Gasket - Heat Exchanger Door

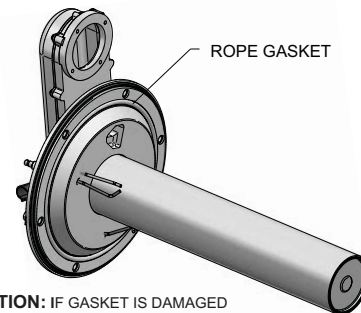

**CAUTION:** IF GASKET IS DAMAGED DO NOT REUSE, THE HEAT EXCHANGER DOOR MUST BE REPLACED.

#### **NOTICE**

Rope gasket is intended for sealing combustion (FIG. 9-3). If damaged DO NOT reuse, the heat exchanger door must be replaced. Consult factory for replacement heat exchanger door (kit WTR3080).

### Oiled bearing circulators

1. The circulator shipped with the outdoor boiler is water-lubricated. No oiling is required.
2. Check other circulators in the system. Oil any circulators requiring oil, following circulator manufacturer's instructions. Over-oiling will damage the circulator.
3. Replace the boiler front access cover.

# 10 Diagrams

Figure 10-1 Ladder Diagram

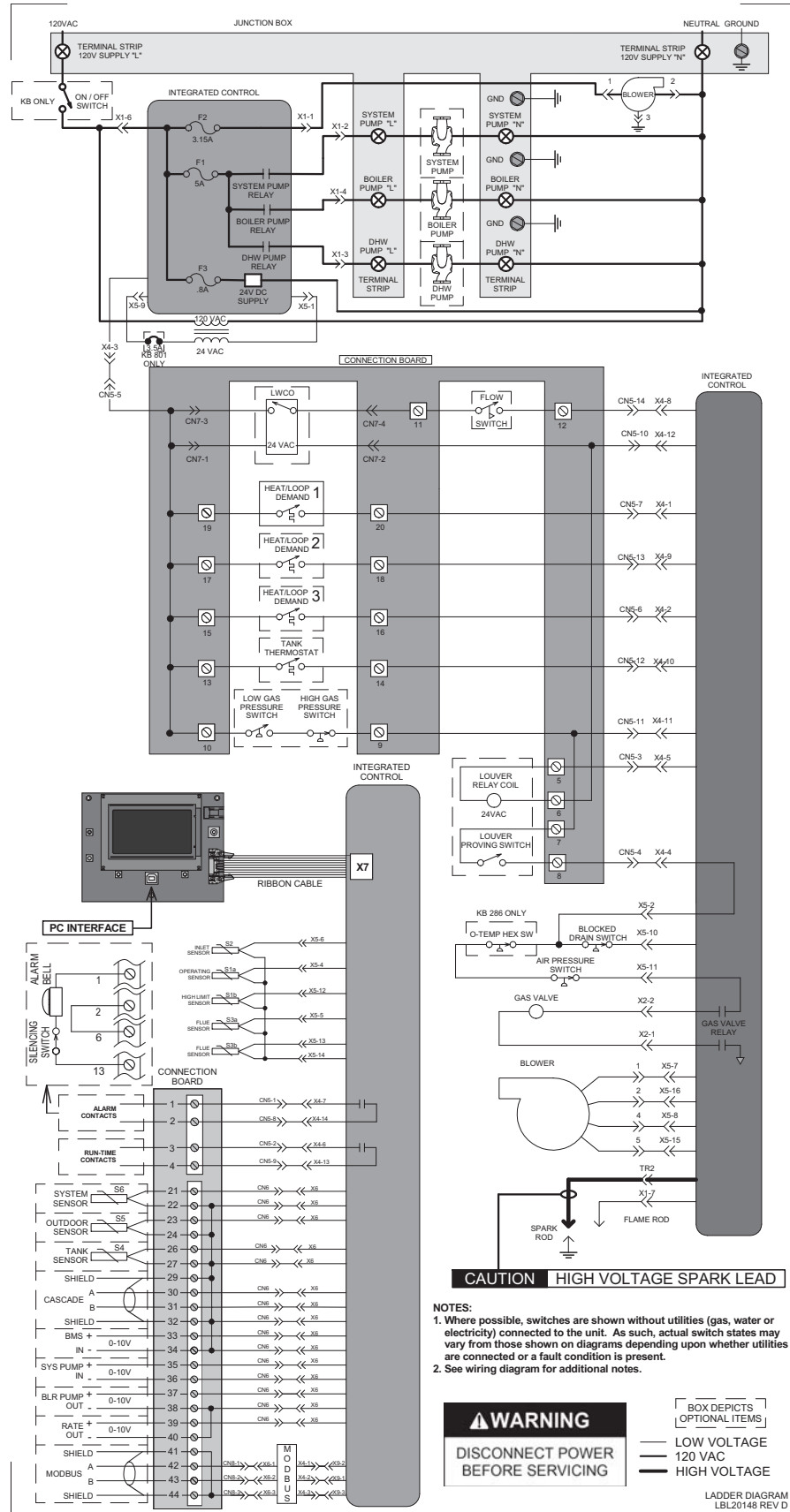



**Revision Notes:** *Revision A (ECO C11234) initial release.*

*Revision B (ECO #C11235) reflects updates made to the freezing conditions warnings.*

*Revision C (ECO #C11736) reflects changes made to the ratings page (page 7).*